



TERMALINE<sup>®</sup> LOAD RESISTOR  
SERIES 8930

OPERATION MANUAL

©COPYRIGHT 2016 BY BIRD TECHNOLOGIES, INC.  
INSTRUCTION BOOK PART NUMBER 920-8930S REV. E

TERMALINE<sup>®</sup> IS A REGISTERED TRADEMARK  
OF BIRD ELECTRONIC CORPORATION

## Safety Precautions

---

The following are general safety precautions that are not necessarily related to any specific part or procedure, and do not necessarily appear elsewhere in this publication. These precautions must be thoroughly understood and apply to all phases of operation and maintenance.

**WARNING**

**Keep Away From Live Circuits**

Operating Personnel must at all times observe general safety precautions. Do not replace components or make adjustments to the inside of the test equipment with the high voltage supply turned on. To avoid casualties, always remove power.

**WARNING**

**Shock Hazard**

Do not attempt to remove the RF transmission line while RF power is present.

**WARNING**

**Do Not Service Or Adjust Alone**

Under no circumstances should any person reach into an enclosure for the purpose of service or adjustment of equipment except in the presence of someone who is capable of rendering aid.

**WARNING**

**Safety Earth Ground**

An uninterruptible earth safety ground must be supplied from the main power source to test instruments. Grounding one conductor of a two conductor power cable is not sufficient protection. Serious injury or death can occur if this grounding is not properly supplied.

**WARNING**

**Resuscitation**

Personnel working with or near high voltages should be familiar with modern methods of resuscitation.

**WARNING**

**Remove Power**

Observe general safety precautions. Do not open the instrument with the power on.

**Safety Symbols**

**WARNING**  
Warning notes call attention to a procedure which, if not correctly performed, could result in personal injury.

**CAUTION**  
Caution notes call attention to a procedure which, if not correctly performed, could result in damage to the instrument.



This symbol indicates that a shock hazard exists if the precautions in the instruction manual are not followed.



The caution symbol appears on the equipment indicating there is important information in the instruction manual regarding that particular area. See page 10 for specific cautions.



This symbol indicates that the unit radiates heat and should not be touched while hot.

**Note:** *Calls attention to supplemental information.*

## Warning Statements

---

The following safety warnings appear in the text where there is danger to operating and maintenance personnel and are repeated here for emphasis.

**WARNING**

The vent plug must be used at all times when the unit is operating or cooling. Failure to do so could result in an explosion or severe burns.

**WARNING**

Turn off ac power and RF power when attaching the power cable.

**WARNING**

Never attempt to connect or disconnect RF equipment from the transmission line while RF power is being applied.  
Leaking RF energy is a potential health hazard.

**WARNING**

Disconnect the unit from all power sources before servicing.  
The unit may be energized from multiple sources.  
The potential for electric shock exists.

**WARNING**

Do not operate with side panel removed. Doing so could result in personal injury.

## Caution Statements

---

The following equipment cautions appear in the text whenever the equipment is in danger of damage and are repeated here for emphasis.

**CAUTION**

Do not block airflow. The air intake vent on the bottom of the load must not be obstructed.

**CAUTION**

This load is designed for operation in a horizontal position only, with the vent plug up. Do not use in any other manner.

**CAUTION**

If installed, connect optional interlock before applying RF power.

**CAUTION**

Check the local electrical code for proper ac hookup prior to operation of the unit. Make sure the neutral or return hookup is only used for that purpose.

**CAUTION**

Maximum power is 2,500 W when the blower is not running. If the indicator light should turn off, immediately reduce RF power to less than 2,500 W.

**CAUTION**

Use only Bird coolant, P/N 5-1070, to prevent damage to the load.

## Safety Statements

---

### USAGE

ANY USE OF THIS INSTRUMENT IN A MANNER NOT SPECIFIED BY THE MANUFACTURER MAY IMPAIR THE INSTRUMENT'S SAFETY PROTECTION.

### USO

EL USO DE ESTE INSTRUMENTO DE MANERA NO ESPECIFICADA POR EL FABRICANTE, PUEDE ANULAR LA PROTECCIÓN DE SEGURIDAD DEL INSTRUMENTO.

### BENUTZUNG

WIRD DAS GERÄT AUF ANDERE WEISE VERWENDET ALS VOM HERSTELLER BESCHRIEBEN, KANN DIE GERÄTESICHERHEIT BEEINTRÄCHTIGT WERDEN.

### UTILISATION

TOUTE UTILISATION DE CET INSTRUMENT QUI N'EST PAS EXPLICITEMENT PRÉVUE PAR LE FABRICANT PEUT ENDOMMAGER LE DISPOSITIF DE PROTECTION DE L'INSTRUMENT.

### IMPIEGO

QUALORA QUESTO STRUMENTO VENISSE UTILIZZATO IN MODO DIVERSO DA COME SPECIFICATO DAL PRODUTTORE LA PROIZIONE DI SICUREZZA POTREBBE VENIRNE COMPROMESSA.

**SERVICE**

SERVICING INSTRUCTIONS ARE FOR USE BY SERVICE - TRAINED PERSONNEL ONLY. TO AVOID DANGEROUS ELECTRIC SHOCK, DO NOT PERFORM ANY SERVICING UNLESS QUALIFIED TO DO SO.

**SERVICIO**

LAS INSTRUCCIONES DE SERVICIO SON PARA USO EXCLUSIVO DEL PERSONAL DE SERVICIO CAPACITADO. PARA EVITAR EL PELIGRO DE DESCARGAS ELÉCTRICAS, NO REALICE NINGÚN SERVICIO A MENOS QUE ESTÉ CAPACITADO PARA HACERLO.

**WARTUNG**

ANWEISUNGEN FÜR DIE WARTUNG DES GERÄTES GELTEN NUR FÜR GESCHULTES FACHPERSONAL.

ZUR VERMEIDUNG GEFÄHRLICHER, ELEKTRISCHER SCHOCKS, SIND WARTUNGSARBEITEN AUSSCHLIEßLICH VON QUALIFIZIERTEM SERVICEPERSONAL DURCHZUFÜHREN.

**ENTRETIEN**

L'EMPLOI DES INSTRUCTIONS D'ENTRETIEN DOIT ÊTRE RÉSERVÉ AU PERSONNEL FORMÉ AUX OPÉRATIONS D'ENTRETIEN. POUR PRÉVENIR UN CHOC ÉLECTRIQUE DANGEREUX, NE PAS EFFECTUER D'ENTRETIEN SI L'ON N'A PAS ÉTÉ QUALIFIÉ POUR CE FAIRE.

**ASSISTENZA TECNICA**

LE ISTRUZIONI RELATIVE ALL'ASSISTENZA SONO PREVISTE ESCLUSIVAMENTE PER IL PERSONALE OPPORTUNAMENTE ADDESTRATO. PER EVITARE PERICOLOSE SCOSSE ELETTRICHE NON EFFETTUARE ALCUNA RIPARAZIONE A MENO CHE QUALIFICATI A FARLA.

**CONNECT INTERLOCK TO TRANSMITTER/GENERATOR/AMPLIFIER BEFORE OPERATING.**

**BRANCHER LE VERROUILLAGE À L'ÉMETTEUR/GÉNÉRATEUR/AMPLIFICATEUR AVANT EMPLOI.**

**CONECTE EL INTERBLOQUEO AL TRANSMISOR/GENERADOR/AMPLIFICADOR ANTES DE LA OPERACION.**

**VOR INBETRIEBNAHME VERRIEGELUNG AM SENDER/GENERATOR/VERSTÄRKER ANSCHLIESSEN.**

**PRIMA DI METTERE IN FUNZIONE L'APPARECCHIO, COLLEGARE IL DISPOSITIVO DI BLOCCO AL TRASMETTITORE/GENERATORE/AMPLIFICATORE.**



## About This Manual

---

This manual covers the models listed below:

Connector	115 VAC	230 VAC
Female LC	8931-115	8931-230
1-5/8" EIA Flanged	8932-115	8932-230
3-1/8" EIA Flanged	8936-115	8936-230
3-1/8" Unflanged, Flush Center	8937-115	8937-230
3-1/8" Unflanged, Recessed Center	8938-115	8938-230

## Changes to this Manual

---

We have made every effort to ensure this manual is accurate. If you discover any errors, or if you have suggestions for improving this manual, please send your comments to our Solon, Ohio factory. This manual may be periodically updated. When inquiring about updates to this manual refer to the part number and revision on the title page.

## Chapter Layout

---

**Introduction** — Describes the features of the Bird Termaline RF Load Resistor lists equipment supplied and optional equipment, and provides power-up instructions.

**Theory of Operation** — Describes how the Termaline RF Load Resistor works and its functions.

**Installation** — Describes the how to install the Termaline RF Load Resistor.

**Operation with Blower** — Describes procedures require for operating the load resistor equipped with a blower unit.

**Maintenance** — Lists routine maintenance tasks as well as troubleshooting for common problems. Specifications and parts information are also included.

# TABLE OF CONTENTS

<b>Safety Precautions</b> .....	<b>i</b>
<b>Warning Statements</b> .....	<b>iii</b>
<b>Caution Statements</b> .....	<b>iv</b>
<b>Safety Statements</b> .....	<b>v</b>
<b>About This Manual</b> .....	<b>viii</b>
Changes to this Manual .....	viii
Chapter Layout .....	viii
<b>Chapter 1 Introduction</b> .....	<b>1</b>
Items Supplied .....	1
Items Required but not Supplied .....	1
Optional Accessories .....	1
<b>Chapter 2 Theory of Operation</b> .....	<b>2</b>
Load Resistor .....	2
Coolant .....	2
Fans .....	2
Power Rating Reduction .....	2
Thermal Interlock .....	2
<b>Chapter 3 Installation</b> .....	<b>3</b>
Unpacking and Inspection .....	3
Mounting .....	3
Setup .....	3
Thermoswitch .....	4
Interlock Connection .....	5
AC Power Connection .....	6
Connecting RF Power .....	6
Swivel Flanged Coupling .....	6
Unflanged Coupling .....	7
<b>Chapter 4 Operating Instructions</b> .....	<b>8</b>
Blower Controls .....	8
Normal Operation .....	8
Operation Under Abnormal Conditions .....	8
Emergency Shutdown .....	8
<b>Chapter 5 Maintenance</b> .....	<b>9</b>
Troubleshooting .....	9
Maintenance .....	10
Cleaning .....	10
Inspection .....	11
RF Assembly Resistance Test .....	11
Coolant .....	12
Repair .....	12
RF Connector .....	13
Load Resistor .....	13
Indicator Light .....	13

Fuse ..... 14

Fans ..... 15

Storage and Shipment ..... 15

Customer Service ..... 16

Specifications ..... 17

Replacement Parts ..... 18

Available "QC" Type Connectors ..... 19

**Limited Warranty ..... 20**

Bird 8930 Series Loads are general purpose, 50 ohm, coaxial RF transmission line terminations, useful as standby reject loads for single or double sideband transmitters. They provide accurate, dependable, and low reflection line terminations over a frequency range of DC – 1000 MHz. Up to 10,000 watts can be dissipated.

The loads have a coolant chamber surrounded by radiator fins. The front and rear fins form mounting flanges which can be used as supports for freestanding use or as brackets for fixed mounting. A vent plug at the top of the unit relieves internal pressure from coolant expansion. A blower with three axial fans is on the bottom of the load. The load's simple and rugged design minimizes maintenance requirements.

## Items Supplied

- Load Resistor: Pre-filled with coolant at the factory
- Detachable 3-wire power cable (without male plug for 230 VAC power cable)
- One Shipping Plug
- One Vent Plug
- Instruction Manual

## Items Required but not Supplied

- Coupling Kit: Connects the load to the RF line
- Male plug for the power cable (230 VAC only)

## Optional Accessories

- Interlock Thermoswitch: Automatically shuts off the transmitter to prevent overheating of the load

**Figure 1 Bird 8930 Series Outline Drawing**

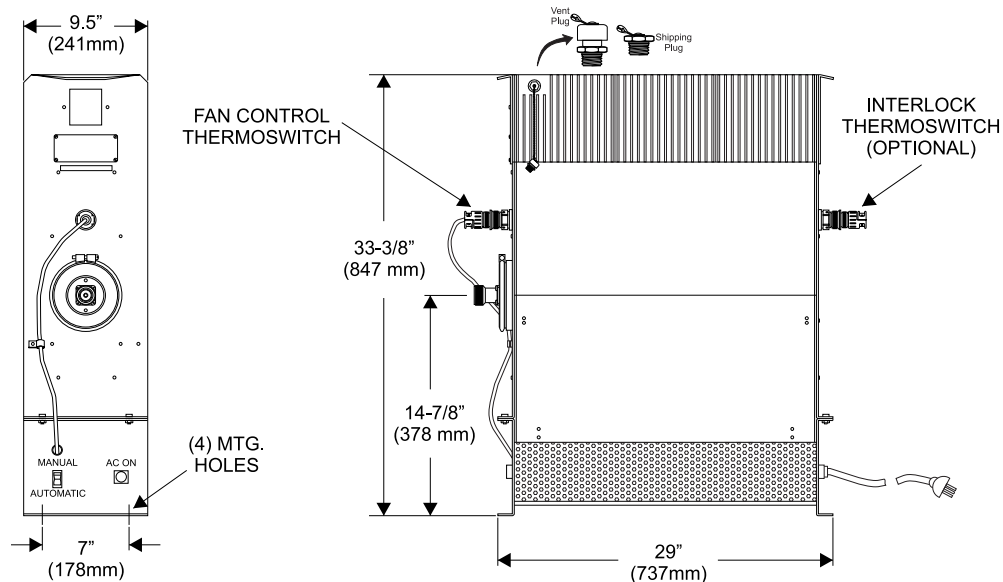

## Load Resistor

---

Bird 8930 Loads consist of a thin-film-on-ceramic resistor immersed in a dielectric coolant. The resistor, individually selected for its accuracy, is enclosed in a special housing. When surrounded by the coolant, this produces a uniform, practically reflection-less line termination over the specified frequencies.

## Coolant

---

The load is cooled by forced air and natural fluid convection currents. The coolant, chosen for its desirable dielectric and thermal characteristics, carries heat from the resistor to the walls of the cooling tank, where radiator fins surrounding the tank transfer the heat to the forced air flow.

When the coolant is heated, thermal expansion causes an increase in the internal pressure. A vent plug relieves this pressure while protecting the opening from dirt or other contaminants.

## Fans

---

Forced airflow is provided by three axial fans beneath the heat exchanger. Baffles direct the air over the radiator fins for more efficient cooling. A passive, normally open control thermostat closes when the coolant reaches 60 °C (140 °F), turning the fans on.

## Power Rating Reduction

---

The baffles interfere with the free flow of normal air currents, causing a 75% reduction in heat transfer efficiency if the forced airflow is stopped. The maximum power dissipation when the fans are not functioning is 2.5 kW.

## Thermal Interlock

---

When installed, a passive, normally closed over-temperature thermostat opens above the maximum safe load temperature of 226 °C (439 °F), turning off transmitter power. The interlock will not permit use of the transmitter until the load has reached a safe temperature.

## Unpacking and Inspection

---

1. Carefully inspect shipping container for signs of damage.
  - If the shipping container is damaged, do not unpack the unit. Immediately notify the shipping carrier and Bird Technologies.
  - If the shipping container is not damaged, unpack the unit. Save shipping materials for repackaging.
2. Inspect unit for visual signs of damage.

**Note:** *If there is damage, immediately notify the shipping carrier and Bird Technologies.*

## Mounting

---

**CAUTION**

Do not block airflow. The air intake vent on the bottom of the load must not be obstructed.

Place the load in a dry, dust and vibration free environment. Do not use outdoors or in areas of condensing humidity. Allow at least 15" (40 cm) of clearance on all sides of the load, or mount it over a suitably reinforced opening measuring 26"L x 7"W x 5"D (660 x 178 x 127 mm).

**CAUTION**

This load is designed for operation in a horizontal position only, with the vent plug up. Do not use in any other manner.

Bird 8930 Loads are intended for stationary or fixed use. The mounting brackets on front and rear faces have four mounting holes arranged in a 7" x 27<sup>23</sup>/<sub>32</sub>" (114.3 x 526.3 mm) rectangle. Use a screw with a <sup>3</sup>/<sub>8</sub>" (9.5 mm) diameter max.

## Setup

---

**WARNING**

The vent plug must be used at all times when the unit is operating or cooling. Failure to do so could result in an explosion or severe burns.

- Before first using the load, get a resistance baseline for future maintenance. Refer to "[RF Assembly Resistance Test](#)" on [page 11](#) for instructions.
- Remove the shipping plug from the load and replace it with the vent plug. Refer to [Figure 1](#) for images of the plugs.

## Thermoswitch

Bird 8930 Loads can be equipped with an optional interlock thermoswitch, P/N 8890-017. It is normally closed, opening at 226 °C (439 °F), with a rating of 10A @ 120Vac and 5A @ 230Vac.

A control thermoswitch, P/N 8892-333, is used to control the blower assembly. It is normally open, closing at 60 °C (140 °F), with a rating of 10A @ 120Vac and 5A @ 230Vac.

**WARNING**

The vent plug must be used at all times when the unit is operating or cooling. Failure to do so could result in an explosion or severe burns.

To install or replace a thermoswitch, follow these instructions:

1. Replace the vent plug with the shipping plug.
2. Interlock Thermoswitch: Supporting the load to prevent damage to the RF connector, stand the unit on its front with the connector down. In this position there is no danger of coolant spillage.
3. Control Thermoswitch: Stand the unit on its back end, with the connector up. In this position there is no danger of coolant spillage.
4. Remove the socket plug (or old thermoswitch), using a  $\frac{9}{16}$ " hex wrench.
5. Insert the new thermoswitch. Sparingly apply pipe sealing compound to the external threads, only, of the thermoswitch. Do not contaminate the coolant with pipe sealant.
6. Check for coolant leaks upon completion.

## Interlock Connection

---

If installed, connect the optional interlock thermoswitch to the interlock as follows (see [Figure 2](#)):

**CAUTION**  
If installed, connect optional interlock before applying RF power.

1. Unscrew the larger knurled ring-nut (A) at the lower end of the coupling jack assembly. Pull it off the thermoswitch jack (B). Unscrew the small knurled cover fitting (C) from the base plug (D) of the connector to release the base.
2. Thread the interlock wires through the clamp (E) with the washers (F) inside and with its threaded fitting in place. Service the interlock wires with short tips and put spaghetti sleeves over the wire ends if necessary.
3. Securely solder the interlock leads to the lugs (G) of the connector base.

**Note:** The ring-nut (A) must be in place over the base plug (D) with the knurled end facing out.

4. Screw on the cover fitting (C), then fasten the cable clamp (E) in place and tighten both yoke screws (H).
5. Put the plug back on the thermoswitch and tighten the nut (A).

**Figure 2** Thermoswitch Connections

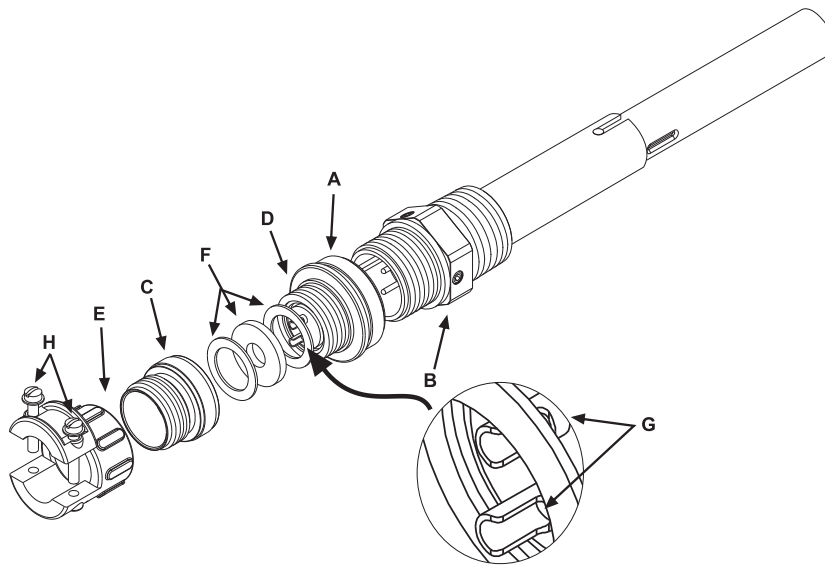



## AC Power Connection

### CAUTION

Check the local electrical code for proper ac hookup prior to operation of the unit.  
Make sure the neutral or return hookup is only used for that purpose.

### WARNING

Turn off ac power and RF power when attaching the power cable.

The AC power supply required for this unit is 115/230 V, depending on the model, @ 50/60 Hz, 1 $\phi$ . The blower is equipped with an IEC 320 "cold" (65 °C) AC inlet.

## Connecting RF Power

After installing the load, the RF transmission line can be attached using standard coaxial line coupling kits.

### WARNING

Never attempt to connect or disconnect RF equipment from the transmission line while RF power is being applied.  
Leaking RF energy is a potential health hazard.

**"QC" Connector Coupling** — Use 50 ohm coaxial cable such as RG-218/U or -220/U (-17A or -19A), appropriate for the frequency and power level of operation. Use a cable connector which will mate with the one on the load.

## Swivel Flanged Coupling

To couple the swivel flange with a flanged RF transmission line, use an appropriate coupling kit. Refer to [Figure 3](#) while following the instructions below:

**Figure 3 Swivel Flanged Coupling**

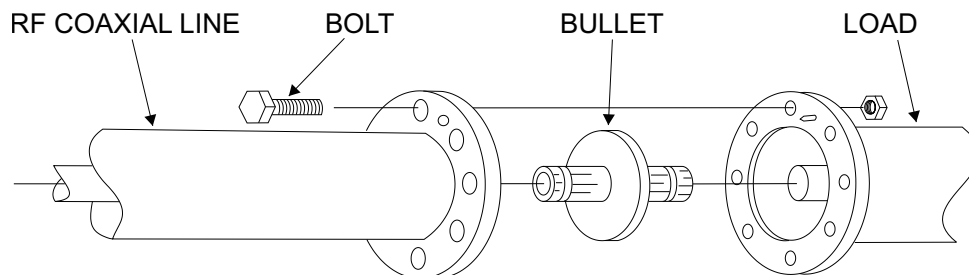

- Insert the center bullet and push it in until it is fully seated.
- Connect the coaxial input in a straight line and push carefully on the center conductor to close.

**Note:** The swivel flange on the load makes connection independent of the orientation of the fixed flange on the coaxial input outer conductor.

- Insert the bolt sets and tighten evenly all around to transmission line manufacturer's recommended torque. Use all of the bolts.

## Unflanged Coupling

---

To couple the unflanged connector with an unflanged RF line, use an appropriate coupling kit. Refer to [Figure 4](#) while following the instructions below:

**Figure 4** *Unflanged Coupling*

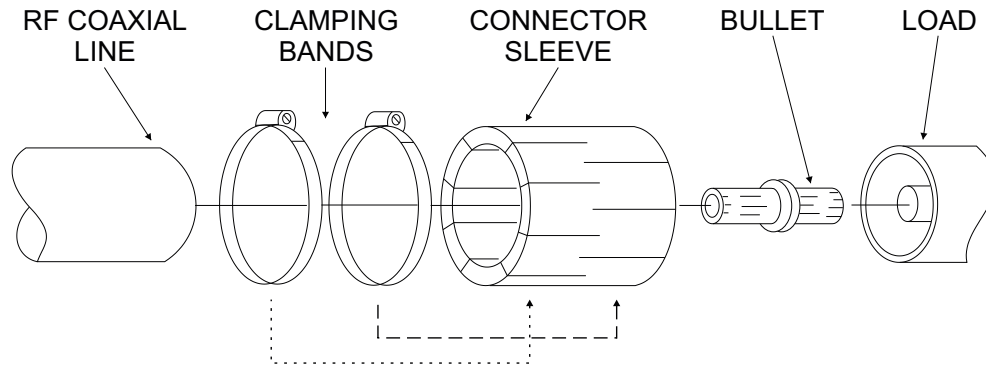

- Insert the center bullet and bottom it on the midpoint nibs.
- Position the outer sleeve, with clamping bands, over the input connector.
- Set the transmission line snugly against the coupling stops.
- Position the clamping bands evenly about 3/4" from the ends of the sleeve.
- Tighten the clamping bands.

**CAUTION**

Maximum power is 2,500 W when the blower is not running. If the indicator light should turn off, immediately reduce RF power to less than 2,500 W.

**WARNING**

Never attempt to connect or disconnect RF equipment from the transmission line while RF power is being applied.  
Leaking RF energy is a potential health hazard.

## Blower Controls

---

Bird 8930 Loads are equipped with a control switch and indicator light on the front of the blower, underneath the RF connector. The switch is labeled "MANUAL/AUTOMATIC". When the switch is set to MANUAL, the fans will run continuously. When set to AUTOMATIC, the fans will be turned on when the coolant reaches a preset temperature. The indicator light, labeled "AC ON", will turn on whenever the unit is connected to ac power.

## Normal Operation

---

- Check that the indicator light is on.
- Set the switch to MANUAL momentarily to check that the fans are working properly, then set the switch back to AUTOMATIC.
- Apply RF power.

## Operation Under Abnormal Conditions

---

If the indicator light turns off or the fans stop unexpectedly, immediately turn off RF power or reduce it to less than 2,500 W. Refer to "[Troubleshooting](#)" on page 9 to correct the problem. A properly connected interlock will prevent overload.

The load can be subjected to higher power levels for short intervals. If this is likely, make sure the interlock is properly connected to prevent damage to the load.

- Shutdown
- Turn off RF power at the source.
- Wait approximately 15 minutes, or for the fans to stop running. This will allow the load to cool without causing heat stress.
- Turn off the blower.

## Emergency Shutdown

---

Turn off RF power at the source.

If the interlock thermoswitch is properly connected, RF power will be automatically turned off when the coolant temperature reaches an unsafe level.

**WARNING**  
 Disconnect the unit from all power sources before servicing.  
 The unit may be energized from multiple sources.  
 The potential for electric shock exists.

**WARNING**  
 Never attempt to connect or disconnect RF equipment from the transmission line while RF power is being applied.  
 Leaking RF energy is a potential health hazard.

### Troubleshooting

The table below contains troubleshooting information for problems which can occur during normal operation. This manual cannot list all malfunctions that may occur, or their corrective actions. If a problem is not listed or is not corrected by the listed actions, notify a qualified service center.

PROBLEM	POSSIBLE CAUSE	CORRECTION
No air flow from blowers; "BLOWER ON" light off	Unplugged power cable	Connect the power cable
	No ac power	Make sure ac power is properly connected and turned on
	Fuse burnout	Replace fuse after correcting the burnout cause (See <a href="#">"Fuse" on page 14</a> )
No air flow from blowers; "BLOWER ON" light on	Fan obstructed by bent grill	Straighten the grill
	Fan motors overheated	Clean the grill and fan blades (See <a href="#">"Cleaning" on page 10</a> )
	Fan motors burnt out	Replace fan ( <a href="#">"Fans" on page 15</a> )
Air flow from blowers; "BLOWER ON" light off	Lamp burnout	Replace lamp (See <a href="#">"Indicator Light" on page 13</a> )
Leaking coolant	Loose clamping band	Tighten the clamping band
	Defective or improperly installed O-ring	Replace the O-ring (See <a href="#">"Load Resistor" on page 13</a> )
High or low DC resistance	Loose RF input connector	Tighten connector
	Faulty RF input connector	Model 8931: Replace connector (See <a href="#">"RF Connector" on page 13</a> )
		All other models: Return the unit for service
Overheating radiator	Faulty resistor	Replace the resistor (See <a href="#">"Load Resistor" on page 13</a> )
	RF power too high	Lower RF power (See <a href="#">"Specifications" on page 17</a> for maximum RF power)
	Coolant level too low	Check the coolant level. Add coolant if necessary (See <a href="#">"Coolant" on page 12</a> )
	Coolant degraded	Replace coolant (See <a href="#">"Coolant" on page 12</a> )
	Faulty control thermoswitch	Replace control thermoswitch (See <a href="#">"Thermoswitch" on page 4</a> )
	Faulty resistor	Replace the load resistor (See <a href="#">"Load Resistor" on page 13</a> )

## Maintenance

**Note:** [Figure 5 on page 10](#) shows the location of components which may be referred to in this section.

**Figure 5 Maintenance and Repair Locations**

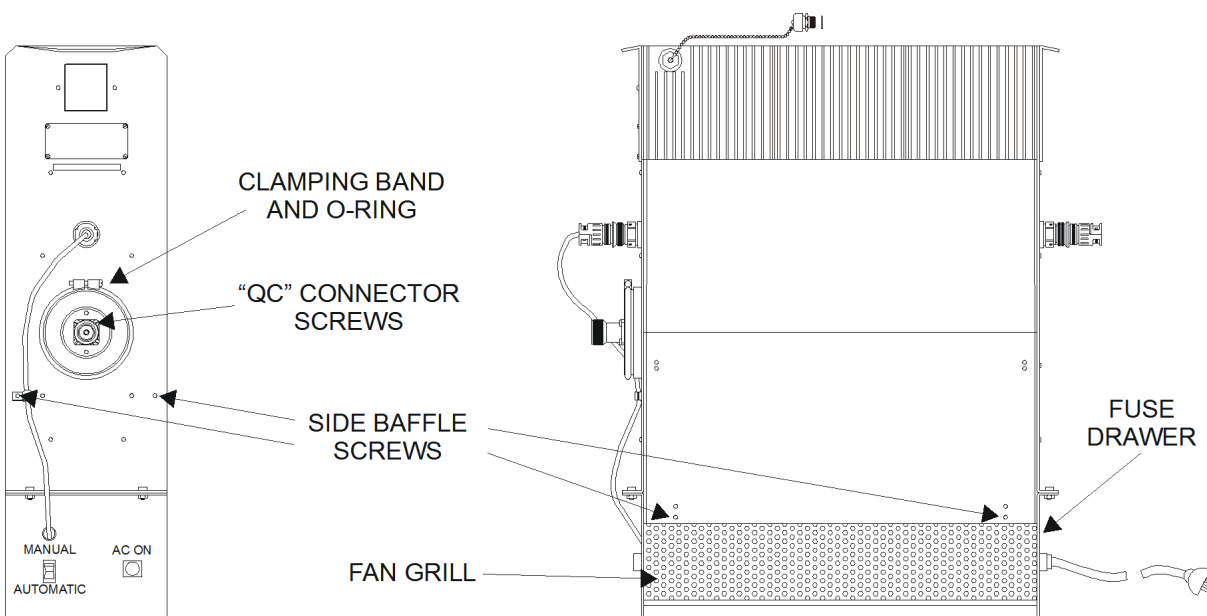

## Cleaning

The outside surface of the unit should be wiped free of dust and dirt when necessary. Excessive dust on the cooling fins will interfere with heat dissipation. Clean the RF connector, both metallic and insulating surfaces, with a dry, non-residue forming solvent.

### WARNING

Disconnect the unit from all power sources before servicing.  
The unit may be energized from multiple sources.  
The potential for electric shock exists.



### WARNING

Do not operate with side panel removed. Doing so could result in personal injury.

## Radiator

To clean the radiator fins, partial disassembly of the load will be required. Follow the instructions below:

1. Unscrew the unpainted 10-32 x  $\frac{1}{4}$ " Phillips head screws on the front and rear radiator faces, just below the RF connector.
2. Unscrew all four pairs of 10-32 x  $\frac{5}{8}$ " Phillips head screws on the sides of the radiator, just above the fan grill.
3. Remove the side panels and clean the fins.
4. Replace the side panels and screw into place.

## Fans

Follow these steps to clean the fans:

1. Pull the fan grill out so that its upper flanges come free from the housing.
2. Pull the grill down and remove it.
3. Use a soft, damp cloth to remove dust from both sides of the fan blades. Do not use a cleaning solution that will attack the plastic parts of the fan.
4. Replace the fan grill.

## Inspection

---

Inspect the unit every six months. Check for coolant leakage around the clamping band and the thermostwitch. Also check for corrosion.

## RF Assembly Resistance Test

---

**Note:** *These tests are by no means a necessity to the operation of the load but merely guidelines for the users information.*

Accurate measurement of the DC resistance between the inner and outer conductors of the RF input connector will provide a good check of the condition of the load resistor.

Checking the DC resistance is simply used to measure a change in the resistance over time. Tracking the DC resistance should start *before* the unit is first put into service. Perform the following steps and record the value for future comparison. Resistance measurements should be taken periodically according to use.

Preparation:

- Tools: Common hand tools.
- Ohmmeter with an accuracy of  $\pm 1\%$  at 50 ohms (or use a resistance bridge).
- Use low resistance leads, preferably a short piece of 50 ohm coaxial cable fitted with an appropriate connector or alligator clips.
- Temperature of the load should be stabilized between 20°C to 25°C (68°F to 77°F).

## DC Resistance Measurement

**WARNING**

Never attempt to connect or disconnect RF equipment from the transmission line while RF power is being applied.  
Leaking RF energy is a potential health hazard.

**Note:** *It is recommended that this resistance check be performed each time the load is to be used.*

1. Turn off RF power and interlock circuitry before making any disconnections.
2. Disconnect the RF coaxial line.
3. Connect the multimeter test leads across the center and outer conductor of the load resistor. See [Figure 6](#).
4. Record the value of the resistance *before* the load is put into service. Compare subsequent values with the latest reading. If the values vary more than 2 ohms this could be an indication of a failing resistive element.

**Figure 6 Measuring DC Resistance**

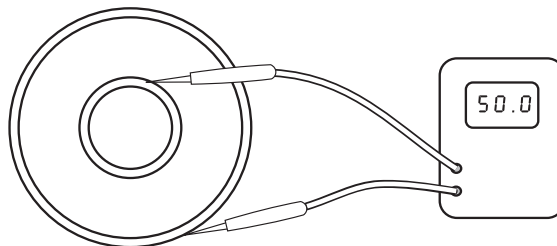

## Coolant

Coolant lifetime will vary greatly depending on the operating temperature. For heavy use (full RF power for long times, high ambient temperature, 50 Hz ac supply), check the coolant every 500 hours. If the load has only had light duty (fraction of full power, low ambient temperature, 60 Hz ac supply), then coolant inspection may only be necessary every 2,000 hours.

**Note:** Correct any coolant leakage before inspection. (See “Troubleshooting” on page 11)

**WARNING**  
 Disconnect the unit from all power sources before servicing.  
 The unit may be energized from multiple sources.  
 The potential for electric shock exists.

To inspect the coolant:

- ★ Remove the load resistor (Refer to “Load Resistor” on page 18).

**CAUTION**  
 Use only Bird coolant, P/N 5-1070, to prevent damage to the load.

- ★ The coolant should be clear, with a faint yellow tinge, and have a slightly sweet smell. If it is black with a burnt or acrid smell, drain it and add about 6.7 gal (25.4 L) of coolant.
- ★ With the load still on end, the coolant level should be 4<sup>3</sup>/<sub>4</sub> to 5 inches (125 mm) below the top of the resistor assembly mounting ring, at ambient temperature. Add coolant if necessary.

## Repair

**Note:** [Figure 5 on page 10](#) shows the location of components which may be referred to in this section.

**WARNING**  
 Disconnect the unit from all power sources before servicing.  
 The unit may be energized from multiple sources.  
 The potential for electric shock exists.

## RF Connector

---

The Model 8931, *only*, has a Bird “QC” connector which allows easy changing of the RF connector. This does not disturb the coolant seal or affect the electrical continuity of the load. To change the connector:

- Remove the four screws at the corners of the RF connector.
- Pull the connector straight out.
- Push the new connector in. Make sure that the center pin on the connector is properly seated in the mating socket on the load.
- Replace the screws.

**Note:** *If not using the LC connector normally supplied, frequency and power must be limited to the capabilities of the connector.*

## Load Resistor

---

To change the load resistor assembly:

1. Remove the vent plug and install the shipping plug.
2. Stand the unit on its back with the connector end up. In this position there is no danger of the coolant pouring out through the socket plug hole.
3. Unscrew and remove the clamping band.
4. Lift the load resistor assembly out of the tank and allow any coolant to drip back into the tank.
5. Check the O-Ring. It should be free of twists and positioned evenly around the flange of the resistor housing. If the O-ring shows signs of deterioration (e.g. is no longer pliable or has surface cracks) replace it.
6. Replace the entire load resistor assembly. It cannot be further disassembled.
7. Put the clamping band in place and tighten it.
8. Remove the shipping plug and install the vent plug.

## Indicator Light

---

**WARNING**

Disconnect the unit from all power sources before servicing.  
The unit may be energized from multiple sources.  
The potential for electric shock exists.

1. Remove the four 8-32 pan head screws from the front and back of the base frame.
2. Pull the fan guard straight off the bottom.
3. Remove the quick disconnects on the light and unscrew the retaining sleeve.
4. Remove the light unit.
5. Remove the lens while pressing both locking tabs.
6. Press the housing’s center slot with a small screwdriver to release the lamp.
7. Push the new lamp into the housing until it snaps into place.
8. Replace the lens, then put the light unit back in place.
9. Replace the fan guard and screw it into place.



## Fuse

The fuse is located in the AC module on the back of the blower.

To replace the fuse:

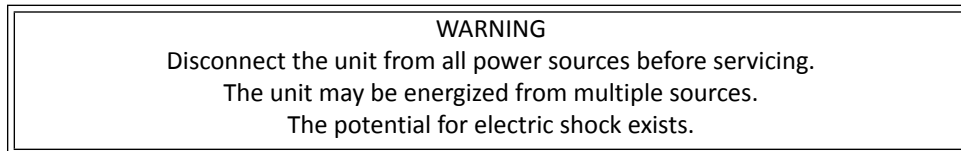

1. Correct the fuse burnout cause.

**Note:** Common causes include stuck or blocked fans or a short circuit in the motor or blower wiring.

2. Press the locking tab on the fuse drawer and remove the drawer.
3. Replace the fuse. See "[Specifications](#)" on page 17 for fuse type and current rating.
4. Press the drawer into the AC module until it locks into place.
5. If the fans still do not run or if the fuse burns out again, return the unit to Bird for service.

**Figure 7** Wiring Diagram

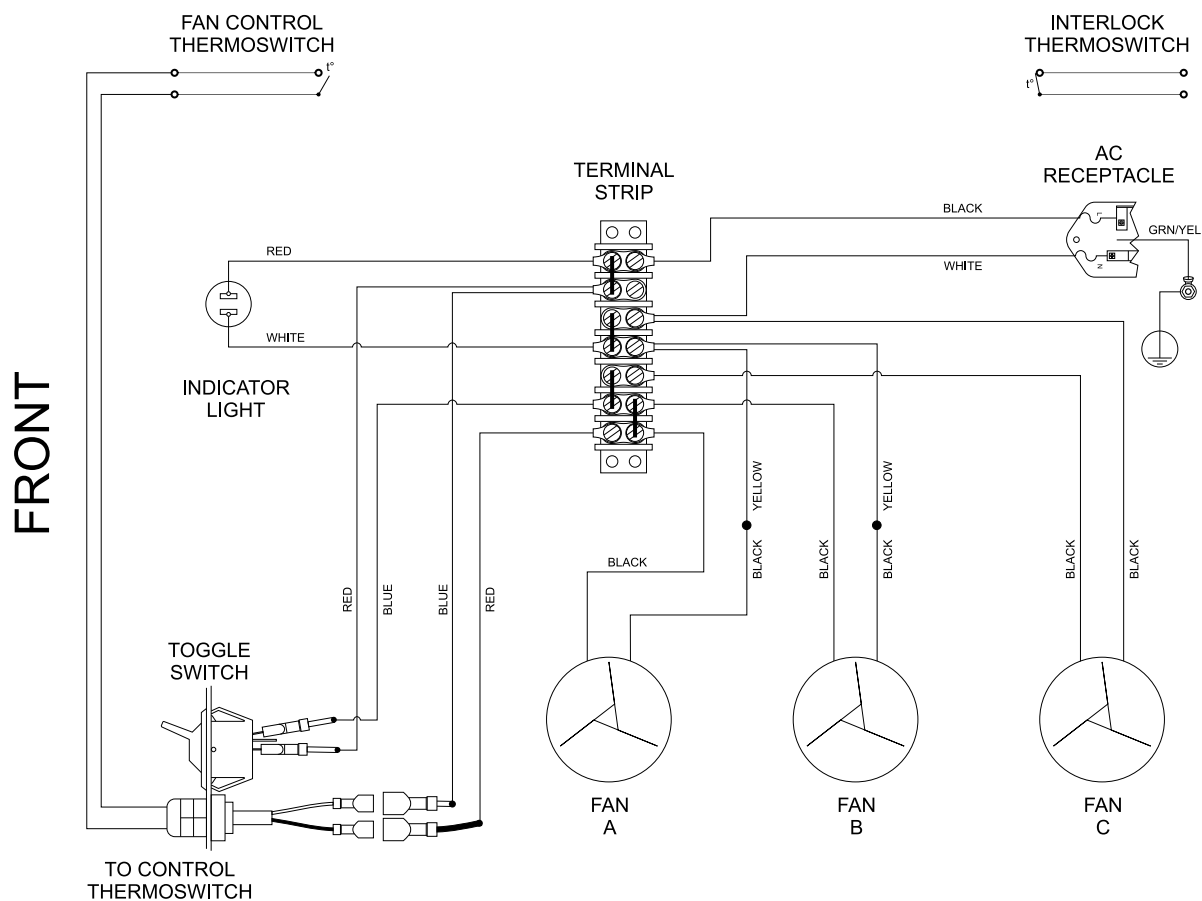

## Fans

---

When ordering a replacement fan, be sure to specify the model, the fan part number, ac voltage, and fan position. The fan will be provided with lugs and leads of the right length for direct attachment to the terminal block.

**Note:** *Different fans are used in the 115V and 230V loads. Also, the fan style depends on its position in the blower; A is in front, B is in the middle, and C is at the rear, nearest the terminal block.*

To replace a fan, follow these instructions:

**WARNING**  
Disconnect the unit from all power sources before servicing.  
The unit may be energized from multiple sources.  
The potential for electric shock exists.

1. Pull the fan grill out so that its upper flanges come free from the housing, then pull it down and remove it.
2. On the terminal block, remove the lugs and leads for the defective fan. All L1 leads go to terminals 5 and 6, and all L2 leads to terminals 2 and 3.

**Note:** *It may be necessary to loosen the harness clamps on the other fans to release the required wires.*

3. Remove the four fan mounting screws and remove the fan.
4. Insert the replacement fan in the same position and orientation, and replace the screws.
5. Connect the leads to the terminal block. All L1 leads go to terminals 5 and 6, and all L2 leads to terminals 2 and 3.
6. Replace the fan grill.
7. Connect the unit to ac power. Set the switch to MANUAL momentarily to check that the fans are working properly, then set it back to AUTOMATIC.

## Storage and Shipment

---

Cover the load before storing to keep out dust and dirt. It is not necessary to install the shipping plug. Store in a dry, dust-free environment where the ambient temperature will remain between -40 and +45 °C (-40 to +113 °F).

To ship the load, take the following precautions:

- Remove the vent plug and install the shipping plug. Wrap the vent plug with padding and tape it to the side of the load for protection.

**Note:** With the shipping plug installed, it is not necessary to empty out the coolant.

- Wrap the connector in padding.
- Pack and brace the load in a sturdy wooden crate for shipment.

## Customer Service

---

Any maintenance or service procedure beyond the scope of those in this chapter should be referred to a qualified service center.

If the unit needs to be returned for any reason, request an Return Material Authorization (RMA) through the Bird Technologies website. All instruments returned must be shipped prepaid and to the attention of the RMA number.

### **Bird Service Center**

30303 Aurora Road  
Cleveland (Solon), Ohio 44139-2794  
Fax: (440) 248-5426  
E-mail: [bsc@birdrf.com](mailto:bsc@birdrf.com)

For the location of the Sales Office nearest you, visit our Web site at:

<http://www.birdrf.com>

## Specifications

Frequency Range	DC – 1000 MHz
Power Rating	10 kW continuous duty
Peak Power for Pulse Width*	
1 μs	150 kW
10 μs	120 kW
100 μs	85 kW
1000 μs	55 kW
5000 μs	30 kW
Impedance	50 ohms
VSWR	
DC – 400 MHz	1.15 max
400 – 1000 MHz	1.2 max
Connectors	
8931	Female LC
8932	1-5/8" EIA Flanged
8936	3-1/8" EIA Flanged
8937	3-1/8" Unflanged
8938	3-1/8" Unflanged, Recessed Center Conductor
AC Power	
–115	115 V +10, –6% @ 50/60 Hz ±3%
–230	230 V +10, –6% @ 50/60 Hz ±3%
AC Line Power Rating	460 W max
Fuse Rating	IEC (5 x 20 mm) Type T
115 Vac	3.15 A
230 Vac	1.25 A
Thermoswitch	
Interlock	Normally closed. Opens at 226 °C (439 °F)
Fan Control	Normally open. Closes at 60 °C (140 °F)
Thermoswitch Rating	
115 Vac	10 A
230 Vac	5 A
Ambient Temperature <sup>†</sup>	–40 to +45 °C (–40 to +113 °F) @ 60 Hz –40 to +40 °C (–40 to +104 °F) @ 50 Hz
Altitude <sup>‡</sup>	1520 m (5000 ft.)
Humidity	95% noncondensing max
Cooling method	Oil dielectric and forced air convection
Dimensions	29 <sup>7</sup> / <sub>8</sub> " L x 9.5" W x 33 <sup>3</sup> / <sub>8</sub> " H (759 x 241 x 847 mm)
Weight, Nominal	142 lb. (64.4 kg)
Finish	Grey Powder Coat

\* Set the duty factor so that the load's average power rating is not exceeded.

† Derate RF power rating by 100 W for every 1 °C (1.8 °F) above 45 °C (113 °F) @ 60Hz, or 40 °C (104 °F) @ 50Hz, up to a maximum of 60 °C (140 °F).

‡ Derate RF power by 250 W for every 305 m (1,000 ft.) above 1,520 m (5,000 ft.), up to a maximum of 3,050 m (10,000 ft.).

## Replacement Parts

DESCRIPTION	QTY	PART NUMBER
RF Load Resistor		
8931		8931-117
8932	1	8932-117
8936		8936-117
8937		8937-117
8938		8938-117
Resistor O-Ring	1	5-230
Clamping Band Assembly	1	2430-055
Plugs		
Vent	1	2450-094
Shipping		2450-049
Interlock Thermoswitch	1	8890-017
Thermoswitch Body	1	8890-015
Thermoswitch Connector Jack	1	2450-018
Control Thermoswitch	1	8892-333
Thermoswitch Body	1	8892-334
Thermoswitch Connector Jack	1	2450-018
Coolant, 5 gal (18.9 L)	1	5-1070-3
Radiator Assembly	1	8921-002
Blower Assembly		
115 V	1	8931A101-1
230 V		8931A101-2
Blower Control Cable	1	8931-135-2
Blower Fan, 85 W		
Fan only, without leads		5-740-1
115 V		5-740-2
230 V		
With Leads		
115 V, Front (A)	3	8931A127-1
115 V, Middle (B)		8931A128-1
115 V, Rear (C)		8931A129-1
230 V, Front (A)		8931A127-2
230 V, Middle (B)		8931A128-2
230 V, Rear (C)		8931A129-2
Blower Base Grille Guard	1	8931A106
Side Panel Assembly	2	8931-103
Fuse		
115 V, 5x20mm Type T, 3.15 A	2	5A2257-21
230 V, 5x20mm Type T, 1.25A		5A2257-17
Neon Lamp		
115 V	1	5A2409-1
230 V		5A2409-2
Switch, Toggle	1	5A2312
AC Line Supply Cable		
115 V	1	8950A023-1
230 V		8950A023-2

## Available “QC” Type Connectors

---

Connector	Part Number
BNC-Female	4240-125
BNC-Male	4240-132
C-Female	4240-100
C-Male	4240-110
HN-Female	4240-268
HN-Male	4240-278
LC-Female*	4240-031
LC-Male	4240-025
Open Term. # 10-32 Nut	4240-080
LT-Female	4240-018
LT-Male	4240-012
N-Female	4240-062
N-Male	4240-063
SC-Female	4240-090
SMA-Female	4240-336
SMA-Male	4240-334
7/16 Jack, IEC Type 169-4	4240-344
7/16 Plug, IEC Type 169-4	4240-363
Mini UHF-Female	4240-346
UHF-Female	4240-050
UHF-Male	4240-179
1-5/8" EIA Fixed	4240-096
1-5/8" EIA Swivel	4240-208
7/8" EIA	4240-002
TNC-Female	4240-156
TNC-Male	4240-160

\* Normally supplied on the 8831

## LIMITED WARRANTY

All products manufactured by Seller are warranted to be free from defects in material and workmanship for a period of one (1) year, unless otherwise specified, from date of shipment and to conform to applicable specifications, drawings, blueprints and/or samples. Seller's sole obligation under these warranties shall be to issue credit, repair or replace any item or part thereof which is proved to be other than as warranted; no allowance shall be made for any labor charges of Buyer for replacement of parts, adjustment or repairs, or any other work, unless such charges are authorized in advance by Seller.

If Seller's products are claimed to be defective in material or workmanship or not to conform to specifications, drawings, blueprints and/or samples, Seller shall, upon prompt notice thereof, either examine the products where they are located or issue shipping instructions for return to Seller (transportation charges prepaid by Buyer). In the event any of our products are proved to be other than as warranted, transportation costs (cheapest way) to and from Seller's plant, will be borne by Seller and reimbursement or credit will be made for amounts so expended by Buyer. Every such claim for breach of these warranties shall be deemed to be waived by Buyer unless made in writing within ten days from the date of discovery of the defect.

The above warranties shall not extend to any products or parts thereof which have been subjected to any misuse or neglect, damaged by accident, rendered defective by reason of improper installation or by the performance of repairs or alterations outside of our plant, and shall not apply to any goods or parts thereof furnished by Buyer or acquired from others at Buyer's request and/or to Buyer's specifications. Routine (regularly required) calibration is not covered under this limited warranty. In addition, Seller's warranties do not extend to the failure of tubes, transistors, fuses and batteries, or to other equipment and parts manufactured by others except to the extent of the original manufacturer's warranty to Seller.

The obligations under the foregoing warranties are limited to the precise terms thereof. These warranties provide exclusive remedies, expressly in lieu of all other remedies including claims for special or consequential damages. SELLER NEITHER MAKES NOR ASSUMES ANY OTHER WARRANTY WHATSOEVER, WHETHER EXPRESS, STATUTORY, OR IMPLIED, INCLUDING WARRANTIES OF MERCHANTABILITY AND FITNESS, AND NO PERSON IS AUTHORIZED TO ASSUME FOR SELLER ANY OBLIGATION OR LIABILITY NOT STRICTLY IN ACCORDANCE WITH THE FOREGOING.