



TERMALINE<sup>®</sup> LOAD RESISTOR  
SERIES 8860

OPERATION MANUAL

©COPYRIGHT 2016 BY BIRD TECHNOLOGIES, INC.  
INSTRUCTION BOOK PART NUMBER 920-8860S REV. D

TERMALINE<sup>®</sup> AND TENULINE<sup>®</sup> ARE REGISTERED TRADEMARKS  
OF BIRD ELECTRONIC CORPORATION

## Safety Precautions

---

The following are general safety precautions that are not necessarily related to any specific part or procedure, and do not necessarily appear elsewhere in this publication. These precautions must be thoroughly understood and apply to all phases of operation and maintenance.

WARNING

**Keep Away From Live Circuits**

Operating Personnel must at all times observe general safety precautions. Do not replace components or make adjustments to the inside of the test equipment with the high voltage supply turned on. To avoid casualties, always remove power.

WARNING

**Shock Hazard**

Do not attempt to remove the RF transmission line while RF power is present.

WARNING

**Do Not Service Or Adjust Alone**

Under no circumstances should any person reach into an enclosure for the purpose of service or adjustment of equipment except in the presence of someone who is capable of rendering aid.

WARNING

**Safety Earth Ground**

An uninterruptible earth safety ground must be supplied from the main power source to test instruments. Grounding one conductor of a two conductor power cable is not sufficient protection. Serious injury or death can occur if this grounding is not properly supplied.

WARNING

**Resuscitation**

Personnel working with or near high voltages should be familiar with modern methods of resuscitation.

WARNING

**Remove Power**

Observe general safety precautions. Do not open the instrument with the power on.

## Safety Symbols

### WARNING

Warning notes call attention to a procedure, which if not correctly performed, could result in personal injury.

### CAUTION

Caution notes call attention to a procedure, which if not correctly performed, could result in damage to the instrument.



This symbol indicates that a shock hazard exists if the precautions in the instruction manual are not followed.



The caution symbol appears on the equipment indicating there is important information in the instruction manual regarding that particular area.



This symbol indicates that the unit radiates heat and should not be touched while hot.

**Note:** *Calls attention to supplemental information.*

## Warning Statements

---

The following safety warnings appear in the text where there is danger to operating and maintenance personnel, and are repeated here for emphasis.

**WARNING**  
The vent plug must be used at all times when the unit is operating or cooling. Failure to do so could result in an explosion or severe burns.

See page 3.

**WARNING**  
Never attempt to connect or disconnect RF equipment from the transmission line while RF power is being applied.  
Leaking RF energy is a potential health hazard.

See pages 5, 7, 8, and 9.

**WARNING**  
Disconnect the unit from all power sources before servicing.  
The unit may be energized from multiple sources.  
The potential for electric shock exists.

See pages 8 and 10.

**WARNING**  
Oil is slippery. If a leak occurs, be careful not to fall.

See pages 8, 8, 10, and 10.

## Caution Statements

---

The following equipment cautions appear in the text and are repeated here for emphasis.

**CAUTION**  
This load is designed for operation in a horizontal position only, with the vent plug up. Do not use in any other manner.

See pages 3.

**CAUTION**  
Do not contaminate the coolant with pipe sealant.

See pages 4.

**CAUTION**  
If installed, connect optional interlock before applying RF power.

See pages 4.

**CAUTION**  
Use only Bird coolant, P/N 5-1070, to prevent damage to the load.

See pages 10.

## Safety Statements

---

### USAGE

ANY USE OF THIS INSTRUMENT IN A MANNER NOT SPECIFIED BY THE MANUFACTURER MAY IMPAIR THE INSTRUMENT'S SAFETY PROTECTION.

### USO

EL USO DE ESTE INSTRUMENTO DE MANERA NO ESPECIFICADA POR EL FABRICANTE, PUEDE ANULAR LA PROTECCIÓN DE SEGURIDAD DEL INSTRUMENTO.

### BENUTZUNG

WIRD DAS GERÄT AUF ANDERE WEISE VERWENDET ALS VOM HERSTELLER BESCHRIEBEN, KANN DIE GERÄTESICHERHEIT BEEINTRÄCHTIGT WERDEN.

### UTILISATION

TOUTE UTILISATION DE CET INSTRUMENT QUI N'EST PAS EXPLICITEMENT PRÉVUE PAR LE FABRICANT PEUT ENDOMMAGER LE DISPOSITIF DE PROTECTION DE L'INSTRUMENT.

### IMPIEGO

QUALORA QUESTO STRUMENTO VENISSE UTILIZZATO IN MODO DIVERSO DA COME SPECIFICATO DAL PRODUTTORE LA PROIZIONE DI SICUREZZA POTREBBE VENIRNE COMPROMESSA.

### **SERVICE**

SERVICING INSTRUCTIONS ARE FOR USE BY SERVICE - TRAINED PERSONNEL ONLY. TO AVOID DANGEROUS ELECTRIC SHOCK, DO NOT PERFORM ANY SERVICING UNLESS QUALIFIED TO DO SO.

### **SERVICIO**

LAS INSTRUCCIONES DE SERVICIO SON PARA USO EXCLUSIVO DEL PERSONAL DE SERVICIO CAPACITADO. PARA EVITAR EL PELIGRO DE DESCARGAS ELÉCTRICAS, NO REALICE NINGÚN SERVICIO A MENOS QUE ESTÉ CAPACITADO PARA HACERLO.

### **WARTUNG**

ANWEISUNGEN FÜR DIE WARTUNG DES GERÄTES GELTEN NUR FÜR GESCHULTES FACHPERSONAL.

ZUR VERMEIDUNG GEFÄHRLICHE, ELEKTRISCHE SCHOCKS, SIND WARTUNGSARBEITEN AUSSCHLIEßLICH VON QUALIFIZIERTEM SERVICEPERSONAL DURCHZUFÜHREN.

### **ENTRETIEN**

L'EMPLOI DES INSTRUCTIONS D'ENTRETIEN DOIT ÊTRE RÉSERVÉ AU PERSONNEL FORMÉ AUX OPÉRATIONS D'ENTRETIEN. POUR PRÉVENIR UN CHOC ÉLECTRIQUE DANGEREUX, NE PAS EFFECTUER D'ENTRETIEN SI L'ON N'A PAS ÉTÉ QUALIFIÉ POUR CE FAIRE.

### **ASSISTENZA TECNICA**

LE ISTRUZIONI RELATIVE ALL'ASSISTENZA SONO PREVISTE ESCLUSIVAMENTE PER IL PERSONALE OPPORTUNAMENTE ADDESTRATO. PER EVITARE PERICOLOSE SCOSSE ELETTRICHE NON EFFETTUARRE ALCUNA RIPARAZIONE A MENO CHE QUALIFICATI A FARLA.

**CONNECT INTERLOCK TO TRANSMITTER BEFORE OPERATING.**

**BRANCHER LE VERROUILLAGE À L'ÉMETTEUR AVANT EMPLOI.**

**CONECTE EL INTERBLOQUEO AL TRANSMISOR ANTES DE LA OPERACION.**

**VOR INBETRIEBNAHME VERRIEGELUNG AM SENDER ANSCHLIESSEN.**

**PRIMA DI METTERE IN FUNZIONE L'APPARECCHIO, COLLEGARE IL DISPOSITIVO DI BLOCCO AL TRASMETTITORE.**



## About This Manual

---

This manual covers the operating and maintenance instructions for the following models:

8860

## Changes to this Manual

---

We have made every effort to ensure this manual is accurate. If you discover any errors, or if you have suggestions for improving this manual, please send your comments to our Solon, Ohio factory. This manual may be periodically updated. When inquiring about updates to this manual refer to the part number and revision on the title page.

## Chapter Layout

---

**Introduction** — Describes the features of the Bird Termaline, Semiconductor, RF Load Resistor lists equipment supplied and optional equipment, and provides power-up instructions.

**Theory of Operation** — Describes how the Termaline, Semiconductor, RF Load Resistor works and its functions.

**Installation** — Describes the how to install the Termaline, Semiconductor, RF Load Resistor.

**Operation with Blower** — Describes procedures require for operating the load resistor equipped with a blower unit.

**Maintenance** — Lists routine maintenance tasks as well as troubleshooting for common problems. Specifications and parts information are also included.

# TABLE OF CONTENTS

<b>Safety Precautions</b> .....	<b>i</b>
Safety Symbols .....	ii
Warning Statements .....	iii
Caution Statements .....	iv
Safety Statements .....	v
<b>About This Manual</b> .....	<b>viii</b>
Changes to this Manual .....	viii
Chapter Layout .....	viii
<b>Chapter 1 Introduction</b> .....	<b>1</b>
Items Supplied .....	1
Items Required but not Supplied .....	1
Optional Accessories .....	1
<b>Chapter 2 Theory of Operation</b> .....	<b>2</b>
Load Resistor .....	2
Coolant .....	2
Thermal Interlock .....	2
<b>Chapter 3 Installation</b> .....	<b>3</b>
Unpacking and Inspection .....	3
Setup .....	3
Mounting .....	3
Installing Thermoswitch .....	4
Interlock Connection .....	4
Connecting RF Power .....	5
“QC” Connector Coupling .....	5
13-30 Coupling .....	5
Swivel Flanged Coupling .....	5
Unflanged Coupling .....	6
<b>Chapter 4 Operating Instructions</b> .....	<b>7</b>
Normal Operation .....	7
Operation Under Abnormal Conditions .....	7
Shutdown .....	7
Emergency Shutdown .....	7
<b>Chapter 5 Maintenance</b> .....	<b>8</b>
Troubleshooting .....	8
Maintenance .....	8
Cleaning .....	8
Inspection .....	9
RF Assembly Resistance Test .....	9
DC Resistance Measurement .....	9
Coolant Level .....	10
Inspecting the Coolant .....	10
Repair .....	10
Replacing the RF Connector .....	10

Replacing the Load Resistor ..... 10

Storage and Shipment ..... 11

    Storing the Load Resistor ..... 11

    Shipping the Load Resistor ..... 11

Customer Service ..... 11

Specifications ..... 12

Replacement Parts ..... 13

Available "QC" Type Connectors ..... 14

**Limited Warranty ..... 15**

Bird 8860 Series Loads are portable 50 ohm coaxial RF transmission line terminations, designed for frequency ranges of DC – 2000 MHz. Bird 8860D Series Loads are identical, except that they are designed for the UHF (470 – 860 MHz) band. They provide accurate, dependable, and low reflection line terminations. Up to 1500 watts of RF power can be dissipated.

The load has a coolant chamber surrounded by radiator fins. The front and rear fins form mounting flanges which can be used as supports for freestanding use or as brackets for fixed mounting. A vent plug at the top of the unit relieves internal pressure from coolant expansion. The load's simple and rugged design minimizes maintenance requirements.

## Items Supplied

- Load Resistor: Pre-filled with coolant at the factory
- Shipping Plug
- Vent Plug
- Instruction Manual

## Items Required but not Supplied

- Coupling Kit: Connects the load to the RF line

## Optional Accessories

- Interlock Thermoswitch: Automatically shuts off the transmitter to prevent overheating of the load

**Figure 1** Bird 8860 Series Outline Drawing

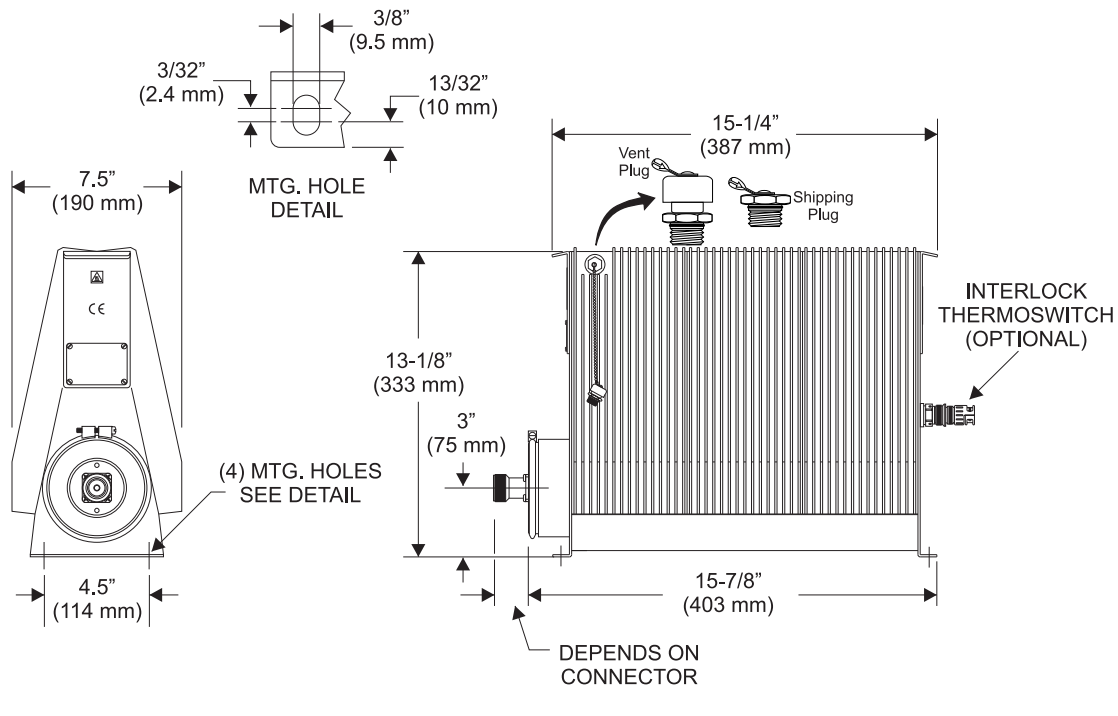

## Load Resistor

---

Bird 8860 Loads consist of a thin-film-on-ceramic resistor immersed in a dielectric coolant. The resistor, individually selected for its accuracy, is enclosed in a special housing. When surrounded by the coolant, this produces a uniform, practically reflectionless line termination over the specified frequencies.

## Coolant

---

The load is cooled by natural fluid and air convection currents. The coolant, chosen for its dielectric and thermal characteristics, carries heat from the resistor to the walls of the cooling tank, where radiator fins surrounding the tank transfer the heat to the air.

When the coolant is heated, thermal expansion causes an increase in the internal pressure. The vent plug relieves this pressure while protecting the opening from dirt or other contaminants.

## Thermal Interlock

---

Loads can be supplied with an optional passive overtemperature thermoswitch. Normally closed, it opens at the maximum safe load temperature of 236 °C (457 °F), turning off transmitter power. The interlock system will not permit reoperation of the transmitter until the load has reached a lower, safe temperature.

This chapter provides information for on-site requirements, unpacking, inspection, and preparing the load for use.

## Unpacking and Inspection

---

1. Carefully inspect shipping container for signs of damage.
  - If the shipping container is damaged, do not unpack the unit. Immediately notify the shipping carrier and Bird Technologies.
  - If the shipping container is not damaged, unpack the unit. Save shipping materials for repackaging.
2. Inspect unit for visual signs of damage.

**Note:** *If there is damage, immediately notify the shipping carrier and Bird Technologies.*

## Setup

---

**Note:** *Before first using the load, get a resistance baseline for future maintenance. Refer to "[RF Assembly Resistance Test](#)" on page 9 for details.*

1. Remove the shipping plug from the load.
2. Replace the shipping plug with the vent plug. Refer to [Figure 1](#) for images of the plugs.

**WARNING**

The vent plug must be used at all times when the unit is operating or cooling. Failure to do so could result in an explosion or severe burns.

## Mounting

---

Place the load in a dry, dust and vibration free environment. Do not use outdoors or in areas of condensing humidity. Allow at least 12" (30 cm) of clearance on all sides of the load.

**CAUTION**

This load is designed for operation in a horizontal position only, with the vent plug up. Do not use in any other manner.

These loads are equipped for either portable use or fixed installation. The mounting brackets on the front and rear faces have four mounting slots arranged in a  $4\frac{1}{2}$ " x  $14\frac{7}{32}$ " rectangle (114.3 x 361.2 mm). Use a screw with a  $\frac{3}{8}$ " (9.53 mm) diameter max.

## Installing Thermoswitch

Bird 8860 series loads can be equipped with an optional interlock thermoswitch, P/N 8890-008. It is normally closed, opening at 236 °C (457 °F), with a rating of 10A @ 120Vac and 5A @ 230Vac.

### WARNING

The vent plug must be used at all times when the unit is operating or cooling. Failure to do so could result in an explosion or severe burns.

1. Remove the vent plug.
2. Install the shipping plug.
3. Stand the unit on its front, supporting it so that the connector is not damaged.

**Note:** *In this position there is no danger of the coolant pouring out through the socket plug hole.*

4. Remove the socket plug just above the connector assembly, using a  $\frac{9}{16}$ " hex wrench.
5. Replace the plug with the thermoswitch.
6. Apply pipe sealing compound to the external threads of the thermoswitch sparingly, ONLY.

### CAUTION

Do not contaminate the coolant with pipe sealant.

7. Check for coolant leaks upon completion.

## Interlock Connection

### CAUTION

If installed, connect optional interlock before applying RF power.

1. Unscrew the large knurled ring-nut (A) at the lower end of the coupling jack assembly.
2. Pull the large knurled ring-nut off the thermoswitch jack (B).
3. Unscrew the small knurled cover fitting from the base plug (D) of the connector to release the base.
4. Thread the control switch wires through the clamp (E) with the washers (F) inside and with its threaded fitting in place.
5. Service the control switch wire with short tips and put spaghetti sleeves over the wire ends if necessary.
6. Securely solder the control switch leads to the lugs (G) of the connector base.

**Note:** *The ring-nut (A) must be in place over the base plug (D) with the knurled end facing out.*

7. Screw on the cover ring, then fasten the cable clamp (E) in place and tighten both yoke screws (H).
8. Put the plug back on the thermoswitch and tighten the nut (A).

Figure 2 Thermoswitch Assembly

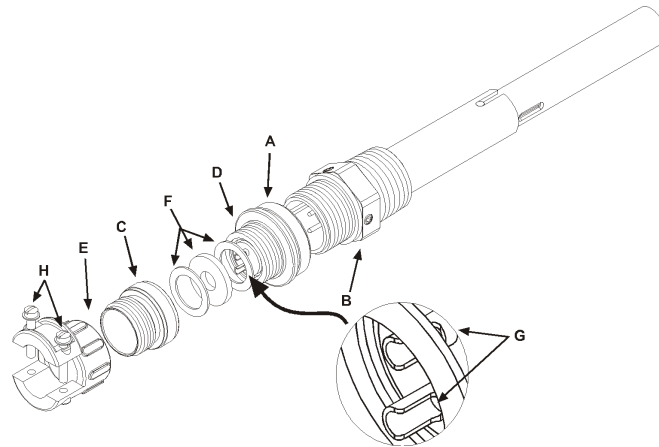

---

## Connecting RF Power

---

After installing the load, the RF transmission line can be attached using standard coaxial line coupling kits.

**WARNING**

Never attempt to connect or disconnect RF equipment from the transmission line while RF power is being applied. Leaking RF energy is a potential health hazard.

---

## “QC” Connector Coupling

---

Use 50 ohm coaxial cable such as RG-218/U or -220/U (-17A or -19A), appropriate for the frequency and power level of operation.

Use a cable connector which will mate with the one on the load.

---

## 13-30 Coupling

---

Use 50 ohm coaxial cable such as RG-8A/U, RG-9U, RG-213/U, or equivalent with a male 13-30 plug.

---

## Swivel Flanged Coupling

---

**Note:** To couple the swivel flange with a flanged RF transmission line, use an appropriate coupling kit. Refer to [Figure 3](#).

1. Insert the center bullet.
2. Push it in until it is fully seated.
3. Connect the coaxial input in a straight line.
4. Push carefully on the center conductor to close.

**Note:** The swivel flange on the load makes connection independent of the orientation of the fixed flange on the coaxial input outer conductor.

5. Insert the bolt sets.
6. Tighten evenly all around to transmission line manufacturer’s recommended torque.

**Note:** Use all of the bolts.

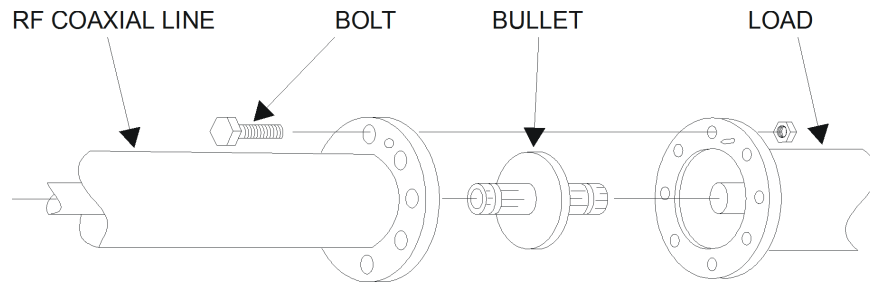
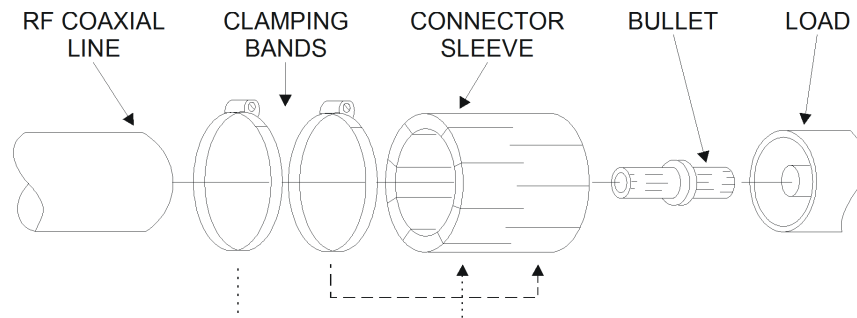

**Figure 3 Swivel Flanged Coupling**

### Unflanged Coupling

To couple the unflanged connector with an unflanged RF line, use an appropriate coupling kit. Refer to [Figure 4](#) while following the instructions below:

1. Insert the center bullet.
2. Bottom it on the midpoint nibs.
3. Position the outer sleeve, with clamping bands, over the input connector.
4. Set the transmission line snugly against the coupling stops.
5. Position the clamping bands evenly about 3/4" from the ends of the sleeve.
6. Tighten the clamping bands.

**Figure 4 Unflanged Coupling**

## Normal Operation

---

Bird 8860 series Loads have no indicators or operating controls. They require no special operating procedures or surveillance when their performance limits are not exceeded. Follow the instructions for the specific transmitter equipment.

## Operation Under Abnormal Conditions

---

The load can be subjected to moderate overloads for short periods. If this is likely, make sure the interlock is properly connected to prevent damage to the load.

## Shutdown

---

These loads are passive devices, so have no way of being turned off. Turn off RF power at the source.

**WARNING**

Never attempt to connect or disconnect RF equipment from the transmission line while RF power is being applied. Leaking RF energy is a potential health hazard.

## Emergency Shutdown

---

Turn off RF power at the source.

If the interlock thermostitch is properly connected, RF power will be automatically turned off when the coolant temperature reaches an unsafe level.

This chapter covers cleaning, inspection, trouble-shooting, and specifications for the Bird 8860 series loads.

**WARNING**

Never attempt to connect or disconnect RF equipment from the transmission line while RF power is being applied. Leaking RF energy is a potential health hazard.

**WARNING**

Disconnect the unit from all power sources before servicing. The unit may be energized from multiple sources. The potential for electric shock exists.

**WARNING**

Oil is slippery. If a leak occurs, be careful not to fall.

## Troubleshooting

---

The table below contains troubleshooting information for problems which can occur during normal operation. This manual cannot list all malfunctions that may occur, or their corrective actions. If a problem is not listed or is not corrected by the listed actions, notify a qualified service center.

Problem	Possible Cause	Correction
Leaking coolant	Loose clamping band	Tighten the clamping band
	Defective or improperly installed O-ring	Replace the O-ring (See " <a href="#">Replacing the Load Resistor</a> " on page 10)
High or low DC resistance	Loose RF connector	Tighten connector
	Faulty RF input connector	Model 8860: Replace connector (See " <a href="#">Replacing the RF Connector</a> " on page 10)
		All other models: Return the unit for service
Faulty resistor	Replace the resistor (See " <a href="#">Replacing the Load Resistor</a> " on page 10)	
Overheating radiator	RF power too high	Lower RF power
	Coolant level too low	Check the coolant level. Add coolant if necessary (See " <a href="#">Coolant Level</a> " on page 10)
	Coolant degraded	Replace the coolant (See " <a href="#">Coolant Level</a> " on page 10)
	Faulty resistor	Replace the resistor (See " <a href="#">Replacing the Load Resistor</a> " on page 10)

## Maintenance

---

### Cleaning

---

The outside surface of the instrument should be wiped free of dust and dirt when necessary. Excessive dust on the cooling fins will interfere with heat dissipation. Clean the RF connector, both metallic and insulating surfaces, with a dry, non-residue forming solvent.

**WARNING**

Oil is slippery. If a leak occurs, be careful not to fall.

## Inspection

---

Inspect the unit every six months. Check for coolant leakage around the clamping band and the thermoswitch. Also check for corrosion.

## RF Assembly Resistance Test

---

**Note:** *These tests are by no means a necessity to the operation of the load but merely guidelines for the users information.*

Accurate measurement of the DC resistance between the inner and outer conductors of the RF input connector will provide a good check of the condition of the load resistor.

Checking the DC resistance is simply used to measure a change in the resistance over time. Tracking the DC resistance should start *before* the unit is first put into service. Perform the following steps and record the value for future comparison. The resistor should provide at least 5,000 hours of operation before requiring any additional service. DC resistance should be measured annually.

Preparation:

- Tools: Common hand tools.
- Ohmmeter with an accuracy of  $\pm 1\%$  at 50 ohms (or use a resistance bridge).
- Use low resistance leads, preferably a short piece of 50 ohm coaxial cable fitted with an appropriate connector or alligator clips.
- Temperature of the load should be stabilized between 20°C to 25°C (68°F to 77°F).

## DC Resistance Measurement

---

**WARNING**

Never attempt to connect or disconnect RF equipment from the transmission line while RF power is being applied.  
Leaking RF energy is a potential health hazard.

**Note:** *It is recommended that this resistance check be performed each time the load is to be used.*

1. Turn off RF power and interlock circuitry before making any disconnections.
2. Disconnect the RF coaxial line.
3. Connect the multimeter test leads across the center and outer conductor of the load resistor. See [Figure 5](#).
4. Record the value of the resistance *before* the load is put into service. Compare subsequent values with the latest reading. If the values vary more than 1 ohm this could be an indication of a failing resistive element.

**Figure 5** *Measuring DC Resistance*

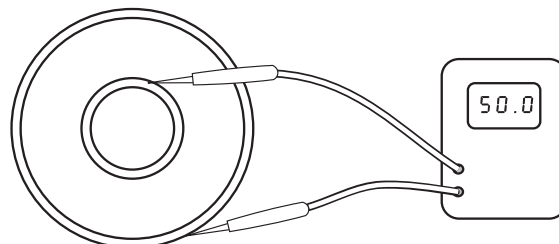

## Coolant Level

Coolant lifetime will vary greatly depending on the operating temperature. For heavy use (full RF power for long times, high ambient temperature), check the coolant every 500 hours. If the load has only had light duty (fraction of full power, low temperature), then inspection may only be necessary every 2,000 hours.

### WARNING

Disconnect the unit from all power sources before servicing. The unit may be energized from multiple sources. The potential for electric shock exists.

### WARNING

Oil is slippery. If a leak occurs, be careful not to fall.

### CAUTION

Use only Bird coolant, P/N 5-1070, to prevent damage to the load.

## Inspecting the Coolant

1. Remove the load resistor.
2. Inspect the coolant.
  - The coolant should be clear, with a faint yellow tinge, and have a slightly sweet smell. If it is black with a burnt or acrid smell, drain it and add about 2.9 gal (11 L) of coolant.
  - With the load still on end, the coolant level should be  $3\frac{5}{8}$ " (92 mm) below the top surface of the resistor assembly mounting ring, at ambient temperature.
3. Add coolant if necessary.

## Repair

### WARNING

Disconnect the unit from all power sources before servicing. The unit may be energized from multiple sources. The potential for electric shock exists.

## Replacing the RF Connector

The Model 8860, *only*, has a special Bird "QC" connector which allows easy changing of the RF connector. This does not disturb the coolant seal or affect the electrical continuity of the load. To change the connector, proceed as follows:

1. Remove the four screws at the corners of the RF connector.
2. Pull the connector straight out.
3. Push the new connector in.

**Note:** *Make sure that the center pin on the connector is properly seated in the mating socket on the load.*

4. Replace the screws.

**Note:** *If not using the LC connector normally supplied, the frequency and power must be limited to the capabilities of the connector.*

## Replacing the Load Resistor

### WARNING

Oil is slippery. If a leak occurs, be careful not to fall.

1. Remove the vent plug and install the shipping plug.

- Supporting the unit to prevent damage to the interlock, stand it on its back with the connector end up.

**Note:** *In this position there is no danger of the coolant pouring out through the resistor hole.*

- Unscrew and remove the clamping band.
- Lift the load resistor assembly out of the tank and allow any coolant to drip back into the tank.
- The O-Ring should be free of twists and positioned evenly around the flange of the resistor housing.

**Note:** *If the O-ring shows signs of deterioration (e.g. is no longer pliable or has surface cracks) replace it.*

- Replace the entire load resistor assembly.

**Note:** *It cannot be further disassembled.*
- Put the clamping band in place and tighten it.
- Remove the shipping plug and install the vent plug.

## Storage and Shipment

---

### Storing the Load Resistor

---

- Cover Bird 8890 Loads before storing to keep out dust and dirt.
- It is not necessary to install the shipping plug.
- Store in a dry, dust-free environment where the ambient temperature will remain between –40 and +45 °C (–40 to +113 °F).

### Shipping the Load Resistor

---

- Remove the vent plug.
- Install the shipping plug.
- Wrap the vent plug with padding and tape it to the side of the load for protection.

**Note:** *With the shipping plug installed, it is not necessary to empty out the coolant.*
- Wrap the connector in padding.
- Pack and brace the load in a sturdy wooden crate for shipment.

## Customer Service

---

Any maintenance or service procedure beyond the scope of those in this chapter should be referred to a qualified service center.

If the unit needs to be returned for any reason, request an Return Material Authorization (RMA) through the Bird Technologies website. All instruments returned must be shipped prepaid and to the attention of the RMA number.

### Bird Service Center

30303 Aurora Road  
Cleveland (Solon), Ohio 44139-2794  
Fax: (440) 248-5426  
E-mail: [bsc@birdrf.com](mailto:bsc@birdrf.com)

For the location of the Sales Office nearest you, visit our Web site at:

<http://www.birdrf.com>

## Specifications

<b>Frequency Range</b> 8862D, 8862D13-30, 8864D All other models	470 – 860 MHz  DC – 2000 MHz
Power Rating	1500 W continuous duty
Impedance, Nominal	50 ohms
<b>VSWR*</b> 8862D, 8862D13-30, 8864D All other models	1.065  DC – 1 GHz: 1.1 1 – 2 GHz: 1.25
<b>Connectors</b> 8860 8861 8862, 8862D 8862D13-30 8863 8864, 8864D	Female LC 1-5/8" unflanged 1-5/8" EIA flanged Female 13-30 3-1/8" unflanged 3-1/8" EIA flanged
Interlock Thermoswitch	Normally closed. Opens at 236°C (457°F)
<b>Thermoswitch Rating</b> 115 Vac 230 Vac	10 A 5 A
Ambient Temperature	–40 to +45 °C (–40 to +113 °F)
<b>Altitude†</b>	1520 m (5000 ft.)
Humidity	95% noncondensing max
Cooling method	Oil dielectric and convection currents
Dimensions	17.5" L x 7.5" W x 13 <sup>1</sup> / <sub>8</sub> " H (445 x 190 x 334 mm)
Weight, Nominal	27.8 lb. (12.6 kg)
Finish	Grey Powder Coat

\* For model 8860, VSWR is measured using a female type N connector.

† Derate RF power by 250 W for every 305m (1,000 ft.) above 1,520m (5,000 ft.)

## Replacement Parts

---

Description	Qty	Part Number
<b>RF Load Resistor</b>	1	
8860		8890A050
8861		8895-015
8862, 8862D		8892-015
8862D13-30		8862-017
8863		8897-003
8864		8891-050
8864D	8891-071	
Resistor O-Ring	1	5-230
Clamping Band Assembly	1	2430-055
<b>Plug</b>	1	
Vent		2450-094
Shipping		2450-049
Overtemp Thermostat	1	8890-008
Coolant, 1.5 gal (5.7 liter)	1	5-1070-3
Radiator Assembly	1	8860-002
Access Plug 3/4"-14 Hex Socket	1	5020-103



---

**Available “QC” Type Connectors**

---

Connector	Part Number
BNC-Female	4240-125
BNC-Male	4240-132
C-Female	4240-100
C-Male	4240-110
HN-Female	4240-268
HN-Male	4240-278
LC-Female*	4240-031
LC-Male	4240-025
Open Term. # 10-32 Nut	4240-080
LT-Female	4240-018
LT-Male	4240-012
N-Female	4240-062
N-Male	4240-063
SC-Female	4240-090
SMA-Female	4240-336
SMA-Male	4240-334
7/16 Jack, IEC Type 169-4	4240-344
7/16 Plug, IEC Type 169-4	4240-363
Mini UHF-Female	4240-346
UHF-Female	4240-050
UHF-Male	4240-179
1-5/8" EIA Fixed	4240-096
1-5/8" EIA Swivel	4240-208
7/8" EIA	4240-002
TNC-Female	4240-156
TNC-Male	4240-160

\* Normally supplied on the 8860

## LIMITED WARRANTY

All products manufactured by Seller are warranted to be free from defects in material and workmanship for a period of one (1) year, unless otherwise specified, from date of shipment and to conform to applicable specifications, drawings, blueprints and/or samples. Seller's sole obligation under these warranties shall be to issue credit, repair or replace any item or part thereof which is proved to be other than as warranted; no allowance shall be made for any labor charges of Buyer for replacement of parts, adjustment or repairs, or any other work, unless such charges are authorized in advance by Seller.

If Seller's products are claimed to be defective in material or workmanship or not to conform to specifications, drawings, blueprints and/or samples, Seller shall, upon prompt notice thereof, either examine the products where they are located or issue shipping instructions for return to Seller (transportation charges prepaid by Buyer). In the event any of our products are proved to be other than as warranted, transportation costs (cheapest way) to and from Seller's plant, will be borne by Seller and reimbursement or credit will be made for amounts so expended by Buyer. Every such claim for breach of these warranties shall be deemed to be waived by Buyer unless made in writing within ten days from the date of discovery of the defect.

The above warranties shall not extend to any products or parts thereof which have been subjected to any misuse or neglect, damaged by accident, rendered defective by reason of improper installation or by the performance of repairs or alterations outside of our plant, and shall not apply to any goods or parts thereof furnished by Buyer or acquired from others at Buyer's request and/or to Buyer's specifications. Routine (regularly required) calibration is not covered under this limited warranty. In addition, Seller's warranties do not extend to the failure of tubes, transistors, fuses and batteries, or to other equipment and parts manufactured by others except to the extent of the original manufacturer's warranty to Seller.

The obligations under the foregoing warranties are limited to the precise terms thereof. These warranties provide exclusive remedies, expressly in lieu of all other remedies including claims for special or consequential damages. SELLER NEITHER MAKES NOR ASSUMES ANY OTHER WARRANTY WHATSOEVER, WHETHER EXPRESS, STATUTORY, OR IMPLIED, INCLUDING WARRANTIES OF MERCHANTABILITY AND FITNESS, AND NO PERSON IS AUTHORIZED TO ASSUME FOR SELLER ANY OBLIGATION OR LIABILITY NOT STRICTLY IN ACCORDANCE WITH THE FOREGOING.