



TERMALINE<sup>®</sup> LOAD RESISTOR  
SERIES 8792

OPERATION MANUAL

©COPYRIGHT 2017 BY BIRD TECHNOLOGIES, INC.  
INSTRUCTION BOOK PART NUMBER 920-8792/93 REV. A

TERMALINE AND THRULINE ARE REGISTERED TRADEMARKS  
OF BIRD ELECTRONIC CORPORATION

## Safety Precautions

---

The following are general safety precautions that are not necessarily related to any specific part or procedure, and do not necessarily appear elsewhere in this publication. These precautions must be thoroughly understood and apply to all phases of operation and maintenance.

**WARNING**

**Keep Away From Live Circuits**

Operating Personnel must at all times observe general safety precautions. Do not replace components or make adjustments to the inside of the test equipment with the high voltage supply turned on. To avoid casualties, always remove power.

**WARNING**

**Shock Hazard**

Do not attempt to remove the RF transmission line while RF power is present.

**WARNING**

**Do Not Service Or Adjust Alone**

Under no circumstances should any person reach into an enclosure for the purpose of service or adjustment of equipment except in the presence of someone who is capable of rendering aid.

**WARNING**

**Safety Earth Ground**

An uninterruptible earth safety ground must be supplied from the main power source to test instruments. Grounding one conductor of a two conductor power cable is not sufficient protection. Serious injury or death can occur if this grounding is not properly supplied.

**WARNING**

**Resuscitation**

Personnel working with or near high voltages should be familiar with modern methods of resuscitation.

**WARNING**

**Remove Power**

Observe general safety precautions. Do not open the instrument with the power on.

## Safety Symbols

### WARNING

Warning notes call attention to a procedure, which if not correctly performed could result in personal injury.

### CAUTION

Caution notes call attention to a procedure, which if not correctly performed could result in damage to the instrument.



This symbol indicates that a shock hazard exists if the precautions in the instruction manual are not followed.



The caution symbol appears on the equipment indicating there is important information in the instruction manual regarding that particular area.



This symbol indicates that the unit radiates heat and should not be touched while hot.

**Note:** *Calls attention to supplemental information.*

## Warning Statements

---

The following safety warnings appear in the text where there is danger to operating and maintenance personnel and are repeated here for emphasis.

**WARNING**

Never attempt to disconnect RF equipment from the transmission line while RF power is being applied. Leaking HF energy is a potential health hazard.

6, 8, and 9.

**WARNING**

The resistor used in this load consists of a resistive film on a special substrate. If the substrate is broken, there will probably be sharp pieces or splinters inside the load housing. Caution should be exercised to avoid possible injury.

See page 10.

## Caution Statements

The following equipment cautions appear in the text whenever the equipment is in danger of damage and are repeated here for emphasis.

**CAUTION**

The water flow must be kept in the proper direction; incorrect flow will cause almost immediate burnout.

See page 4.

<b>CAUTION</b>			
Do not apply more than rated RF power to the load. The water flow rate and inlet temp. (5° C to 60° C) must be as specified:			
Model	Power	5° C	60° C
8792	80 kW	9 gpm (34 lpm)	12 gpm (45.4 lpm)
Adequate and uninterrupted full water flow is more critical than temperature.			

See page 6.

**CAUTION**

Verify cooling liquid is flowing through the load before RF power is applied and ensure the cooling liquid supply is not interrupted while load is in operation. Even momentary interruption of coolant supply while RF power is applied will cause almost immediate burnout.

See page 6.

**CAUTION**

Never reverse the cooling water connections. It is very important for the safety of the load resistor to observe proper flow direction. Also, when the load is first installed or is reconnected, run the water for approximately one minute to fill the system and remove all air pockets before applying RF power.

See page 6

**CAUTION**

Do not use any pliers or wrenches on the resistor fitting [22] as damage to its surface may result.

See page 14.

## Safety Statements

---

### USAGE

ANY USE OF THIS INSTRUMENT IN A MANNER NOT SPECIFIED BY THE MANUFACTURER MAY IMPAIR THE INSTRUMENT'S SAFETY PROTECTION.

### USO

EL USO DE ESTE INSTRUMENTO DE MANERA NO ESPECIFICADA POR EL FABRICANTE, PUEDE ANULAR LA PROTECCIÓN DE SEGURIDAD DEL INSTRUMENTO.

### BENUTZUNG

WIRD DAS GERÄT AUF ANDERE WEISE VERWENDET ALS VOM HERSTELLER BESCHRIEBEN, KANN DIE GERÄTESICHERHEIT BEEINTRÄCHTIGT WERDEN.

### UTILISATION

TOUTE UTILISATION DE CET INSTRUMENT QUI N'EST PAS EXPLICITEMENT PRÉVUE PAR LE FABRICANT PEUT ENDOMMAGER LE DISPOSITIF DE PROTECTION DE L'INSTRUMENT.

### IMPIEGO

QUALORA QUESTO STRUMENTO VENISSE UTILIZZATO IN MODO DIVERSO DA COME SPECIFICATO DAL PRODUTTORE LA PROIZIONE DI SICUREZZA POTREBBE VENIRNE COMPROMESSA.

**SERVICE**

SERVICING INSTRUCTIONS ARE FOR USE BY SERVICE - TRAINED PERSONNEL ONLY. TO AVOID DANGEROUS ELECTRIC SHOCK, DO NOT PERFORM ANY SERVICING UNLESS QUALIFIED TO DO SO.

**SERVICIO**

LAS INSTRUCCIONES DE SERVICIO SON PARA USO EXCLUSIVO DEL PERSONAL DE SERVICIO CAPACITADO. PARA EVITAR EL PELIGRO DE DESCARGAS ELÉCTRICAS, NO REALICE NINGÚN SERVICIO A MENOS QUE ESTÉ CAPACITADO PARA HACERLO.

**WARTUNG**

ANWEISUNGEN FÜR DIE WARTUNG DES GERÄTES GELTEN NUR FÜR GESCHULTES FACHPERSONAL.

ZUR VERMEIDUNG GEFÄHRLICHE, ELEKTRISCHE SCHOCKS, SIND WARTUNGSARBEITEN AUSSCHLIEßLICH VON QUALIFIZIERTEM SERVICEPERSONAL DURCHZUFÜHREN.

**ENTRETIEN**

L'EMPLOI DES INSTRUCTIONS D'ENTRETIEN DOIT ÊTRE RÉSERVÉ AU PERSONNEL FORMÉ AUX OPÉRATIONS D'ENTRETIEN. POUR PRÉVENIR UN CHOC ÉLECTRIQUE DANGEREUX, NE PAS EFFECTUER D'ENTRETIEN SI L'ON N'A PAS ÉTÉ QUALIFIÉ POUR CE FAIRE.

**ASSISTENZA TECNICA**

LE ISTRUZIONI RELATIVE ALL'ASSISTENZA SONO PREVISTE ESCLUSIVAMENTE PER IL PERSONALE OPPORTUNAMENTE ADDESTRATO. PER EVITARE PERICOLOSE SCOSSE ELETTRICHE NON EFFETTUARRE ALCUNA RIPARAZIONE A MENO CHE QUALIFICATI A FARLA.

**CONNECT INTERLOCK TO TRANSMITTER BEFORE OPERATING.**

**BRANCHER LE VERROUILLAGE À L'ÉMETTEUR AVANT EMPLOI.**

**CONECTE EL INTERBLOQUEO AL TRANSMISOR ANTES DE LA OPERACION.**

**VOR INBETRIEBNAHME VERRIEGELUNG AM SENDER ANSCHLIESSEN.**

**PRIMA DI METTERE IN FUNZIONE L'APPARECCHIO, COLLEGARE IL DISPOSITIVO DI BLOCCO AL TRASMETTITORE.**



## About This Manual

---

This manual covers the operating and maintenance instructions for the following models:

8792

8792-3

## Changes to this Manual

---

We have made every effort to ensure this manual is accurate. If you discover any errors, or if you have suggestions for improving this manual, please send your comments to our Solon, Ohio factory. This manual may be periodically updated. When inquiring about updates to this manual refer to the part number and revision on the title page.

## Terminology

---

There are some unique terms used throughout this literature. They are defined here to clarify any misunderstanding.

**Introduction** — Describes the features of the load resistor, lists equipment supplied and optional equipment, and provides power-up instructions.

**Theory of Operation** — Describes how the load resistor works.

**Installation** — Describes the power supply and load connection instructions.

**Operating Instructions** — Describes the base level operation instructions.

**Maintenance** — Lists routine maintenance tasks as well as troubleshooting for common problems. Specifications and parts information are also included.

# TABLE OF CONTENTS

<b>Safety Precautions</b> .....	<b>i</b>
Safety Symbols .....	ii
Warning Statements .....	iii
Caution Statements .....	iv
Safety Statements .....	v
<b>About This Manual</b> .....	<b>viii</b>
Changes to this Manual .....	viii
Terminology .....	viii
<b>Chapter 1 Introduction</b> .....	<b>1</b>
Purpose and Function .....	1
Description .....	1
Optional Equipment .....	1
Direct Power Measurement .....	1
Emergency and First Aid Procedures for Ethylene Glycol .....	1
<b>Chapter 2 Theory of Operation</b> .....	<b>2</b>
General .....	2
Heat Transfer .....	2
Cooling Water for Models 8792 .....	3
Flow Interlock Control Circuit (Optional) .....	3
<b>Chapter 3 Installation</b> .....	<b>4</b>
Load Resistor Connection .....	4
Water Line Attachment .....	4
Cooling Water Quality .....	4
Flow Switch (Optional) .....	5
Control Box (Optional Item) .....	5
Preoperational Checkout .....	5
<b>Chapter 4 Operating Instructions</b> .....	<b>6</b>
General .....	6
Normal Operation .....	6
Power On Procedure .....	6
Shutdown Procedure .....	6
Operation as an RF Wattmeter .....	7
<b>Chapter 5 Maintenance</b> .....	<b>8</b>
General .....	8
Preventative Maintenance .....	8
Inspection .....	8
Cleaning .....	8
Outside Surface .....	8
RF Connector Surfaces .....	8
Optional Flow Switch .....	8
RF Assembly Resistance Test .....	9
DC Resistance Measurement .....	9
Troubleshooting .....	10

---

Repair ..... 10

- Replacing a Resistive Element ..... 10
- Inspecting the Unit ..... 11
- Replacing Fractured Resistor ..... 12
- Reassembling the Unit ..... 12
- Replacing the RF Connector ..... 14
- Replacing the Water Flow Switch ..... 14
- Replacing the Time Delay Relay ..... 15
- Replacing the Control Box Lamp ..... 15

Storing ..... 16

Shipping ..... 16

Customer Service ..... 16

Specifications ..... 17

Replacement Parts List ..... 18

**Limited Warranty ..... 19**

## Purpose and Function

---

The Model 8792 Termline Load Resistors are designed as compact, low-reflection, and non-radiating termination for RF transmission lines. Cooled by internal water flow, it generates almost no surface heat, making installation space minimal and convenient. They can safely dissipate up to 80 kilowatts of continuous power when used in a 50 ohm coaxial transmission line system.

Each model is designed for use with a standard connector of the types common to 6-1/8 inch coaxial lines, and will maintain a VSWR of less than 1.15 to 1.0 from 1000 Hz up to 800 MHz. These loads are intended for use on CW, AM, FM, SSB, and W modulation envelopes, and within certain limitation on radar or pulse modes. Information on applications involving pulse-type signals should be obtained directly from Bird Electronic Corporation.

## Description

---

The Model 8792 equipment consists of a load resistor unit. They have field replaceable resistive element. The replacement procedure is included in "[Maintenance](#)" on page 8.

## Optional Equipment

---

An accessory protective Control System is available as optional equipment. When properly installed, this system protects the load by shutting off the RF power when water flow is too low or interrupted. Discussions of the flow control pertaining to "[Installation](#)" on page 4 and "[Maintenance](#)" on page 8 should be ignored when not applicable.

## Direct Power Measurement

---

When used in conjunction with a Bird Model 6810 Series Thruline Wattmeter or 3127 Series Panel Meters, these load resistors may be used for direct reading power measurements up to 80 kilowatts.

## Emergency and First Aid Procedures for Ethylene Glycol

---

**Eye Contact** — Immediately flush eyes with plenty of water for at least 15 minutes while holding eyelids open. Get medical attention.

**Skin Contact** — Flush skin with water. If irritation occurs, get medical attention.

**Inhalation** — Remove victim to fresh air and provide oxygen if breathing is difficult. Get medical attention.

**Ingestion** — Do not give liquids if victim is unconscious or very drowsy. Otherwise, give no more than two glasses of water and induce vomiting by giving 30 cc (2 tablespoons) syrup of Ipecac. If Ipecac is unavailable, give two glasses of water and induce vomiting by touching finger to back of victim's throat. Keep victim's head below hips while vomiting. Get medical attention.

## General

---

The load resistor is unique in that it utilizes an external water supply for the direct cooling of the resistor element. By using this technique, the need for an intermediate dielectric fluid to transfer the heat generated in the resistor element has been eliminated, reducing the physical size of the load to a virtual minimum. This simplified system allows the use of the loads in more varied environments, and the attachment in any orientation.

## Heat Transfer

---

The 50 ohm resistor consists of a high temperature substrate tube with a deposited resistive film. The heat generated by absorption of RF power is transferred from the heated film to the water flowing over it, through a restricted chamber surrounding the resistor body. This water, first diverted to the front of the load resistor by a special inside tube passes over the entire length of the resistor and is discharged through the sealed water chamber at the rear. The dielectric characteristics and distinctive design of these enclosures provide a very accurate 50 ohm termination over the specified frequency range of this load - 1000 Hz to 800 MHz.

The absence of intermediate cooling fluids considerably simplifies the construction and sealing of this unit. It can be readily disassembled in the field for resistor element replacement (see "[Maintenance](#)" on page 8).

Because there is practically no heat transfer to the outer housing of the load, the housing remains at a cool ambient temperature even under full power conditions. Virtually all of the power input to the load is transformed into heat which is carried away by the cooling water. Therefore, the differential in output and input temperatures of the water multiplied by the amount of flow constitutes an accurate measurement of the power consumed by the load. The amount of this power dissipation may be calculated from the following formula:

For Celsius Temperatures:  $P = 0.263(T1-T2)GPM$

For Fahrenheit Temperatures:  $P = 0.146(T1-T2)GPM$

Where:

P = Power in Kilowatts

T1 = Outlet Water Temperature

T2 = Inlet Water Temperature

GPM = Water Flow in Gallons Per Minute

## Cooling Water for Models 8792

---

The electrical performance of these RF loads is affected by impurities or other chemical additives in the cooling water. The presence of salts in the water definitely makes the device unusable because salts cause a rapid increase in VSWR. Therefore sea water or silty water should not be used for cooling the loads,

The thermal performance of these loads is also affected by impurities, particularly those impurities that accumulate in the form of scale on the exposed surfaces of the coolant paths of the load assembly. These deposits may result in an increase in the thermal and/or fluid resistance(s) of the load and may in turn cause the load to overheat and fail.

The following types of water are considered safe for the cooling of the Models 8792 Load Resistor: filtered, city, or soft water. In general, any potable water is suitable for cooling the load.

## Flow Interlock Control Circuit (Optional)

---

The interlock control circuit provides instantaneous fail-safe protection of the transmitter and load in the event of even momentary interruption of the cooling water supply. This protection is necessary because dissipation of the heat generated by the RF power absorption is critically dependent upon maintaining the required minimum water flow rate regardless of inlet water temperature.

The water flow switch, attached to the water inlet of the load, is factory calibrated to open the electrical contacts whenever the water flow drops below nine gallons per minute and close when the water flow exceeds this value.

When the water flow switch contacts open, the time delay relay switch is deactivated, which in turn opens the interlock switch causing immediate shutdown of the transmitter or other signal source. The time delay relay also keeps the interlock switch "open" for a  $12 \pm 2$  seconds interval after the minimum flow of nine gallons per minute has been reestablished. This safeguarding feature assures proper operation of the cooling system before RF power can be applied to the load, preventing damage or burnout of the resistive element.

The control assembly also includes a large light on top of the box. The red light should be freely visible from nearly all front angles in the operating vicinity of the load unit/control assembly. After proper installation, as described in ["Installation" on page 4](#), when the light is lit the RF load is ready to receive power, or when not lit indicates trouble in the cooling supply (control).

The compact design of the Model 8792 Termaline Load Resistors enable them to be installed in very small spaces. They require no ventilation and may be placed at any attitude. Do not install them where they may be subjected to severe vibration or to physical shock.

The load is ready for connection as received from the factory. It is useful to first check the 50 ohm input resistance of the load and record this data before attachment, see "[RF Assembly Resistance Test](#)" on page 9.

## Load Resistor Connection

---

Use the following procedure for RF attachment.

**Note:** Use alcohol, freon, or any acceptable dry cleaning solvent on a cloth or cotton swab stick.

1. Clean all conductor and insulator surfaces on the transmission line face and, likewise, the RF input connector.

**Note:** Do not tighten the bolt and nut sets.

2. Attach the load resistor to the RF line.  
Use 6-1/8 inch EIA coupling kit, Bird P/N 4902-020, which includes 12 3/8-16 x 1-3/4 inch bolts, lockwashers, and nut sets, O-Ring, and anchor bullet (center conductor).

3. Rotate the load so that the warning label shows and the outlet water tube is placed to the best advantage.

4. Tighten the RF connection by securing the clamps or bolt sets firmly and evenly.

**Note:** Do not disturb the socket head cap screws that join the connector section to the main housing.

5. Install water inlet and outlet connections. See "[Water Line Attachment](#)" on page 4.

## Water Line Attachment

---

### CAUTION

The water flow must be kept in the proper direction; incorrect flow will cause almost immediate burnout.

The RF Load comes supplied with standard 3/4 inch hose fittings for attaching the water supply and drain lines. The water INLET, at the back on center and water OUTLET, adjacent at a 90 degree angle to the inlet, mate with 3/4 inch water hose connectors.

If the unit is factory equipped with the optional control system, the water flow switch is installed on the water inlet line.

For field installation of the optional control system see [Flow Switch \(Optional\)](#).

To connect to rigid piping, replace the water inlet and outlet hose adapters with 1/2 inch male pipe or pipe fittings, Bird P/N 5-065-2. Take special care when connecting the water lines. The inside of the load is designed so that the water flows properly in only one direction - from the inlet to the outlet. The water flow must be kept in the proper direction - opposite flow will cause resistor failure when power is applied.

## Cooling Water Quality

---

Water quality is important. See "[Cooling Water Quality](#)" on page 4 for an explanation and description. In general, most potable water is satisfactory. This would include purified, filtered, city supply, or soft water.

## Flow Switch (Optional)

---

The ports of the flow switch are 3/4 inch NPT Female. The direction of flow is marked on the casting of the flow tube and on the operating head. Observe carefully, opposite connection will restrict the water flow and cause load failure.

The flow switch may be connected to the inlet or the outlet side of the load, preferably as close to the load as possible. Be certain the flow through the switch is in the correct direction. Connect with a 1/2 inch NPT Nipple and a 1/2 to 3/4 inch bushing, Bird P/N 5-489-1 and 5-490-1, or connect by hose or pipes. In either case, the flow switch should not be over 20 feet from the load. Alternatively, attach hose to switch with a 3/4 inch hose nipple, Bird P/N 5-903.

- Do not connect flow switch leads at this time.
- Turn on the water flow and check the system for leaks and proper operation.

## Control Box (Optional Item)

---

The wiring center and remaining elements of the control system are contained in the control box. This includes a terminal strip and three BX cable clamps for the input connections, a lamp, and a delay timer. Only wiring material is needed for connecting the flow switch to the control box. The control unit operates on 115 VAC, P/N 8750-101-1.

The lamp on top of the box is a safe operation indicator; it lights only when AC power is on and an adequate water supply is flowing. After the pilot lamp lights, a  $12 \pm 2$  second time delay allows sufficient time for the water flow to stabilize before closing the transmitter interlock.

The control box is mounted by means of four 1/4 inch holes on a 5 x 5 inch (127 x 127 mm) square on the back. Locate the box for the best view of the lamp and for easy attachment of the BX cable and wiring.

*Connect the control leads as follows:*

- Water Flow switch leads to terminals 3 and 5.
- Interlock Switch leads to terminals 6 and 7.
- AC power source to terminals 2 and 3.

## Preoperational Checkout

---

Before attempting to operate the RF load, whether under test or actual operating conditions, TEST the complete water system and INTERLOCK CONTROL as follows:

1. Make sure the AC and transmitter interlock power are OFF.
2. Connect an ohmmeter across terminals six and seven (interlock).
3. Turn the AC power on.
4. Turn the water supply on.
5. Note when the water flow switch operates (audible click),

**Note:** *In not less than 10 seconds ( $12 \pm 2$ ) the ohmmeter should signify a closed condition across terminals six and seven, indicating operation of the time delay switch.*

6. Ensure water flow from the OUTLET connection of load is at least 9 gpm (34 lpm) at 5° C (41° F) through 12 gpm (45.4 lpm) at 60° C (140° F).

**Note:** *As a precautionary measure, the Preoperational Checkout should be performed each time the load is put into service.*



## General

---

The Model 8792 Termaline Load Resistors do not have any operating controls, therefore, operator's do not need to be present when in use. Proper operation of the equipment is assured if the instructions contained in "[Installation](#)" on page 4 are followed exactly.

Do not apply more than the rated RF power to the load. The water flow rates 9 - 12 gpm (34 - 45.4 lpm) and inlet water temperature, 5° C to 60° C (41° F to 140° F), must be maintained. In reality, an adequate and uninterrupted water flow is more critical than the actual water temperature.

## Normal Operation

---

### WARNING

Never attempt to disconnect RF equipment from the transmission line while RF power is being applied. Leaking HF energy is a potential health hazard.

### CAUTION

Do not apply more than rated RF power to the load. The water flow rate and inlet temp. (5° C to 60° C) must be as specified:

Model	Power	5° C	60° C
8792	80 kW	9 gpm (34 lpm)	12 gpm (45.4 lpm)

Adequate and uninterrupted full water flow is more critical than temperature.

### CAUTION

Verify cooling liquid is flowing through the load before RF power is applied and ensure the cooling liquid supply is not interrupted while load is in operation. Even momentary interruption of coolant supply while RF power is applied will cause almost immediate burnout.

### CAUTION

Never reverse the cooling water connections. It is very important for the safety of the load resistor to observe proper flow direction. Also, when the load is first installed or is reconnected, run the water for approximately one minute to fill the system and remove all air pockets before applying RF power.

## Power On Procedure

---

1. Turn on the AC power (if the load is equipped with an interlock system).
2. Turn on the water supply (verify water flow rate is sufficient).
3. Check for proper interlock operation (if the load is equipped with an interlock system).
4. Check that all coaxial power line connections are properly tightened.
5. Apply RF power to the load.
6. Proceed according to instructions pertaining to the specific transmitting equipment.

## Shutdown Procedure

---

1. Turn off the RF Power to the load.
2. Wait at least one minute to allow the resistor substrate time to cool.
3. Turn the interlock and AC power off (if the load is equipped with an interlock system).

4. Turn off the water supply.

**Note:** *Always do this last.*

## Operation as an RF Wattmeter

---

The RF load can be combined with a Bird Rigid Line Series Thruline Wattmeter to form an absorption type wattmeter by inserting the wattmeter line section just ahead of the RF load. Installation and operation of the wattmeter is covered in the Thruline Wattmeter Instruction Book.

**Note:** *Select a wattmeter type appropriate to the input connector of the load resistor. Consult the Bird Catalog or contact the Company.*

1. Carry through the same functions detailed in "[Normal Operation](#)" on page 6.
2. Rotate the element in the line section element socket to monitor Incident or Reflected power.

**Note:** *Measurement is taken in the direction indicated by the arrow on the element.*

## General

---

**WARNING**

Never attempt to disconnect RF equipment from the transmission line while RF power is being supplied. Leaking RF energy is a potential health hazard.

The Model 8792 Termaline Coaxial Load Resistors are rugged units of simple design, requiring only nominal and routine attention. The load is designed to operate for long periods of time if care is taken not to exceed its power handling capabilities.

## Preventative Maintenance

---

Due to the basic simplicity of construction, the major requirement for preventive maintenance is to keep the equipment clean.

## Inspection

---

With the rugged and simple construction of the loads, periodic inspection will only be necessary at six-month intervals. Inspection should include the items listed below:

- Cleanliness - Keep the housing and connector free of grime.
- Inspect the load for completeness and general condition of the equipment.
- A Troubleshooting Chart lists the commonly encountered problems, their possible causes and remedies. Use this chart as a guide when analyzing symptoms.

## Cleaning

---

### Outside Surface

The outside surface of these loads should be wiped free of dust and dirt when necessary. Periodically wipe the accumulated dust and lint off of the load housing.

### RF Connector Surfaces

If the Teflon insulator or metallic contact surfaces of the connector should become dirty or grimy, wipe them off with a soft cloth. Use a contact cleaner that is self-drying and leaves no residue to clean the hard to reach internal portions.

**Note:** Always handle the load with care to prevent subjecting it to unnecessary shock or impact.

### Optional Flow Switch

The Water Flow Switch, P/N 5-898-7, should be checked and cleaned of any accumulated dirt on scale that might impede free movement of the control gate in the switch. This should be done after several months use, or if otherwise indicated.

## RF Assembly Resistance Test

---

**Note:** *These tests are by no means a necessity to the operation of the load but merely guidelines for the users information.*

Accurate measurement of the DC resistance between the inner and outer conductors of the RF input connector will provide a good check of the condition of the load resistor.

Checking the DC resistance is simply used to measure a change in the resistance over time. Tracking the DC resistance should start *before* the unit is first put into service. Perform the following steps and record the value for future comparison. Resistance measurements should be taken periodically according to use.

Preparation:

- Tools: Common hand tools.
- Ohmmeter with an accuracy of  $\pm 1\%$  at 50 ohms (or use a resistance bridge).
- Use low resistance leads, preferably a short piece of 50 ohm coaxial cable fitted with an appropriate connector or alligator clips.
- Temperature of the load should be stabilized between 20°C to 25°C (68°F to 77°F).

## DC Resistance Measurement

---

**WARNING**

Never attempt to connect or disconnect RF equipment from the transmission line while RF power is being applied.  
Leaking RF energy is a potential health hazard.

**Note:** *It is recommended that this resistance check be performed each time the load is to be used.*

1. Turn off RF power and interlock circuitry before making any disconnections.
2. Disconnect the RF coaxial line.
3. Connect the multimeter test leads across the center and outer conductor of the load resistor. See [Figure 1](#).
4. Record the value of the resistance *before* the load is put into service. Compare subsequent values with the latest reading. If the values vary more than 2 ohms this could be an indication of a failing resistive element.

*Figure 1 Measuring DC Resistance*

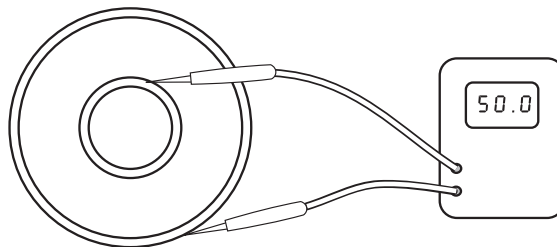

## Troubleshooting

For corrections requiring repair or replacement of components, refer to the appropriate section for your specific model.

Problem	Possible Cause	Correction
Transmitter shuts off or will not stay on.  <b>Note:</b> <i>This applies to units with flow interlock only.</i>	Low or no water flow	Increase cooling water flow.
	Faulty Flow Switch	Perform " <a href="#">Preoperational Checkout</a> " on page 5. If switch fails to operate, replace switch, see " <a href="#">Replacing the Water Flow Switch</a> " on page 14
High load VSWR.	Failing resistor	Perform " <a href="#">RF Assembly Resistance Test</a> " on page 9. Resistance change of greater than 5 ohms indicates a failing resistor. Replace resistor, see " <a href="#">Replacing a Resistive Element</a> " on page 10.
	Loose input connector.	Tighten connector.

## Repair

### Replacing a Resistive Element

This series of water-cooled loads is designed to be quickly and easily repaired in the field. If in performing the [RF Assembly Resistance Test](#) described previously, a significant change in resistance is noted, or if for any reason the resistive element should fail, inexpensive replacement resistors are available. They can be installed in the load, using the following procedures:

#### WARNING

The resistor used in this load consists of a resistive film on a special substrate. If the substrate is broken, there will probably be sharp pieces or splinters inside the load housing. Caution should be exercised to avoid possible injury.

**Note:** *stem numbers enclosed in brackets [ ] in the text are indicated on [Figure on page 16](#), [Figure 3 on page 13](#), and [Figure 4 on page 13](#).*

**Note:** *Turn off RF Power and interlock circuitry prior to proceeding.*

1. Ensure the water flow has been turned off before any disconnection.
2. Disconnect the water hoses at the hose fittings [2] on the load. See [Figure on page 16](#).
3. Disconnect the unit from the RF transmission line.
4. Completely drain excess water from the load.
5. Set the load on end with RF Connector down.
6. Remove the water chamber [1] by unscrewing it in a counterclockwise direction.

**Note:** *A strap wrench and a 3/8 to 1/2 inch rod are useful to overcome the initial tension of the water chamber item [1]. The rod is inserted in the water output hose nipple fitting item [2] for leverage.*

**Note:** *The water inlet tube will usually come out with the water chamber. If not, perform the next step.*

7. Pull the water inlet tube [4] straight off.

- Lift the resistor cap assembly [7] off.

**Note:** *O-Ring tension may cause a restriction and the resistor cap will require gentle prying under the lip with a flat blade or screwdriver.*

- Lift the load resistor [13] straight up and out.

**Note:** *Occasionally, the load resistor will come out with the ground cap assembly due to O-Ring tension.*

**Note:** *At this point, the load resistor may be replaced. To perform this, reverse this procedure and proceed to final assembly if the following criteria is met:*

- The spring fingers on the input resistor fitting [22] ([Figure 4 on page 13](#)) are snug and offer some resistance when the resistor [13] is inserted into the load body.
  - The load resistor has not been fractured or badly burnt in operation. Inspect the resistor thoroughly. However, if either of these conditions are not as stated, further disassembly will be required. Proceed with step [10](#).
- Remove the ground section housing [9] ([Figure 3 on page 13](#)) by grasping it firmly and unscrewing it from the third housing section [11].
  - Unscrew the six 1/4-20 x 1 inch socket head cap screws [20] on the flange.
  - Remove the third housing section [11].

**Note:** *There is no advantage in separating the front and second housing sections. These are removed as an entire unit by removing the six 1/4-20 x 1 inch socket head cap screws on the flange of the front housing [19] ([Figure 4 on page 13](#)). The flow tube [21] may become dislodged and stay with the front resistor fitting [22] when the front housing [19] is removed. If this should happen, just pull it loose from the resistor fitting and push it back into the front housing section*
  - Remove and inspect the following:
    - Resistor fitting [22]
    - Insulator [24]
    - Center conductor assembly [26]
  - Remove the 3/8-16 x 3/4 inch hex head machine screw [27] in the input center conductor [26].
  - Remove the input center conductor assembly.

## Inspecting the Unit

---

**Note:** *Perform this once the resistor has been successfully removed.*

- Inspect the resistor carefully to ensure that it is not fractured.

**Note:** *In the majority of cases, even in the event of resistor failure, the resistor substrate will remain intact.*

- Examine the inside of the load housing assembly for any apparent damage to the internal parts.
- Do one of the following:
  - **If no damage had been found** - Proceed with resistor replacement, [see "Reassembling the Unit" on page 12](#).
  - **If the resistor is broken, other internal parts appear to be damaged, or if they do not fit together properly** - ["Replacing Fractured Resistor" on page 12](#)

## Replacing Fractured Resistor

Wash all the inside portions of the assembly (load housing sections, resistor cap assembly, flow tube, and water chamber) thoroughly under clear running water. Rinse all of the components removed from the load. Reassemble the load with a replacement resistor, see ["Reassembling the Unit" on page 12.](#)

## Reassembling the Unit

Reverse the procedure detailed in ["Replacing a Resistive Element" on page 10.](#)

When replacing the resistor [13] in the resistor fitting [22], be sure it is a very snug fit and requires a moderate force to push the resistor into the fitting. This fit must not be loose and yet not excessively tight.

If the resistor is loose in the fitting [22], performing the following:

1. Press the slotted finger contacts of the fitting together slightly.
2. Try the resistor again.
3. Continue closing the ends of the resistor fitting until a snug even, fit is obtained.
4. Bottom the resistor in the fitting with the resistor in place in the fitting [22].
5. Install the assembly upright in the RF outer conductor [28] or [31].
6. Replace the front housing [19] and continue with reassembly.

Figure 2 Removing the Resistor

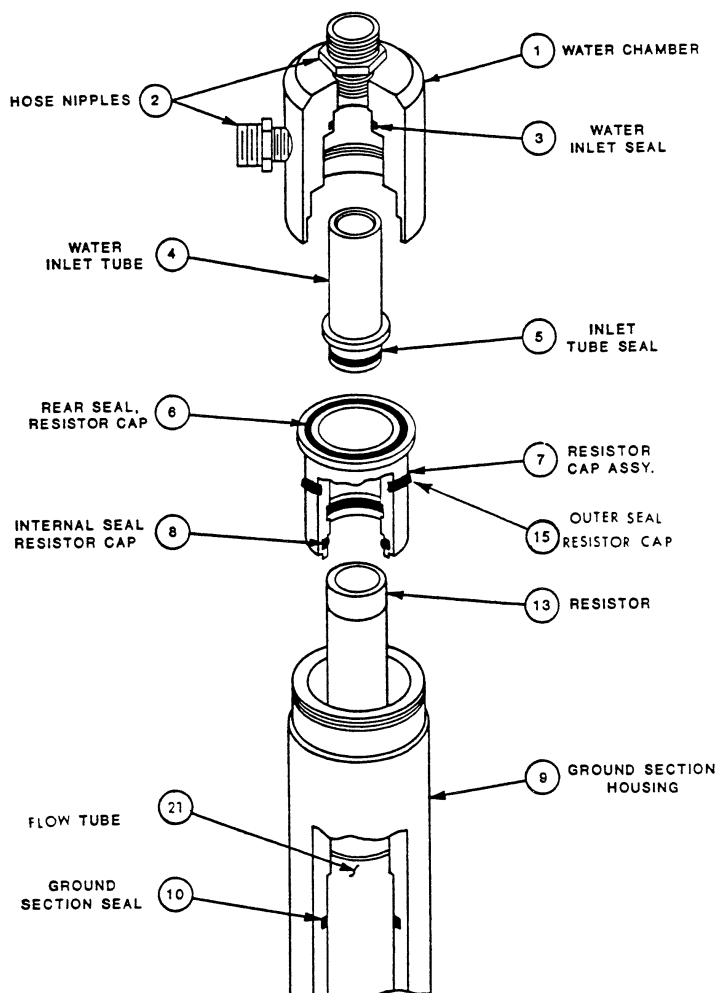

Figure 3 RF Load Midsection

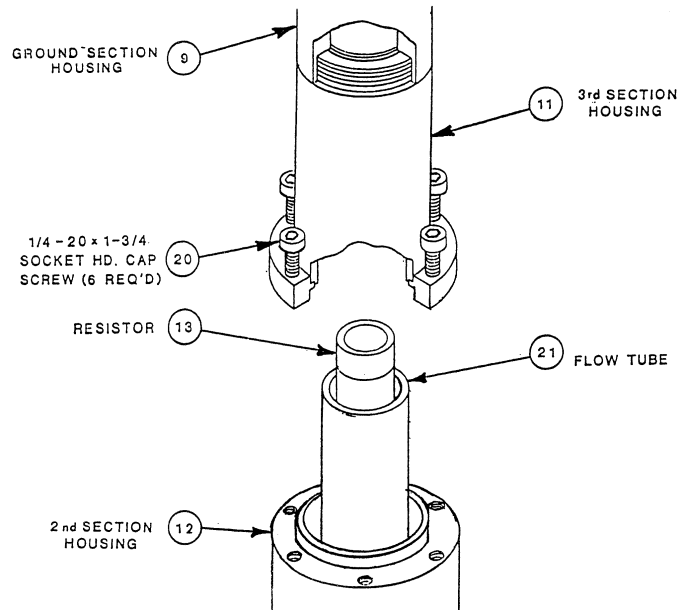
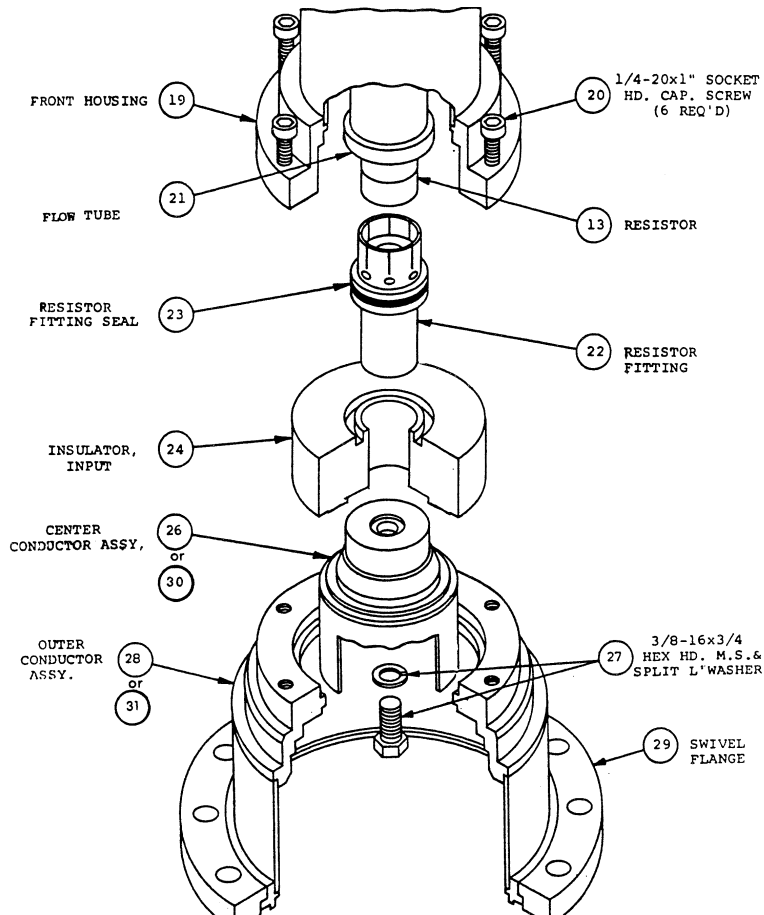

Figure 4 RF input Assembly (Exploded View)





---

## Replacing the RF Connector

---

**Note:** The RF Coaxial connector consists of the inner conductor [26 or 30] and the outer conductor [28 or 31] respectively. See [Figure 4 on page 13](#).

1. Remove the six 1/4-20 x 1 inch socket head cap screws [20] from the flange of the front housing assembly [19]. See [Figure 4 on page 13](#).

**Note:** The outer conductor will come off exposing the center conductor and insulator.

2. Grasp the center conductor assembly and gently pull it off the front housing.

**Note:** Usually the resistor [13] and flow tube [21] will remain in place in the housing when the center conductor assembly is removed. In some cases, one or both of these parts will come out with the center conductor assembly. This is not a problem and they can be separated from the front center conductor assembly and resealed in the housing without consequence.

3. Remove the 3/8-16 x 3/4 inch screw and lock-washer set [27] located inside the center conductor.

**Note:** Use a 5/8 inch socket wrench set with an extension for the screw.

4. Insert a 5/32 inch rod, or equivalent, through the holes in the fitting to hold the resistor fitting [22].

**CAUTION**

Do not use any pliers or wrenches on the resistor fitting [22] as damage to its surface may result.

5. Replace the center conductor assembly by gently manipulating the assembly until it is thoroughly seated in place.
6. Reassemble the RF Connector assembly by reversing this procedure.

---

## Replacing the Water Flow Switch

---

**Note:** Procurement and use of the accessory protective control system (comprising the water flow switch and control box) is optional. The instructions and replaceable parts described in this section are only applicable when the optional equipment is installed.

The water flow switch should be checked and cleaned of any accumulated dirt or scale that might impede free movement of the control gate in the switch. This should be done after several months use, or sooner if indicated by erratic operation. This component is not repairable and if found defective, it must be replaced.

1. Make certain the RF power, AC line power, and the transmitter interlock supply are turned off.
2. Disconnect the leads at the water flow switch.
3. Remove the defective switch from the plumbing.
4. Install the new unit.
5. Reconnect the flow switch leads.
6. Perform the pre-operational checkout. See ["Preoperational Checkout" on page 5](#).

## Replacing the Time Delay Relay

---

**Note:** Procurement and use of the accessory protective control system (comprising the water flow switch and control box) is optional. The instructions and replaceable parts described in this section are only applicable when the optional equipment is installed.

**Note:** The relay cartridge, P/N 5-1664 or 5-1665, in the control box cannot be disassembled or repaired in the field. A faulty unit should simply be replaced using the following Procedure:

1. Ensure the following is shut off:
  - RF power
  - AC line power
  - Transmitter interlock supply
2. Open the door of the control box by turning the slotted screw-head one-quarter turn.
3. Loosen the 8-32 pan head screw at the top of the relay clamp, P/N 8630-193.
4. Press its legs in slightly to release the retaining prongs of clamp.
5. Pull the delay relay cartridge straight out of the socket.
6. Replace the relay by reversing the procedure above.

**Note:** The socket is an ordinary octal type. When inserting the relay, rotate the cartridge carefully to align the center post nub in the socket.

7. Fit the clamp into the slots and turn the head of the screw clockwise until snug.

**Note:** The prongs of the clamp should match the side slots in the socket holder.
8. Close the control box door.
9. Reconnect interlocks and the AC power line by reversing the steps in this procedure.
10. Perform the pre-operational checkout. See "[Preoperational Checkout](#)" on page 5.

## Replacing the Control Box Lamp

---

**Note:** Procurement and use of the accessory protective control system (comprising the water flow switch and control box) is optional. The instructions and replaceable parts described in this section are only applicable when the optional equipment is installed.

1. Locate the lamp (P/N 5-97G (-1 or -2)) on the top of the control box.
2. Push down, gently, and twist the lamp lens (P/N 8750-106).
3. Remove the lamp lens.
4. Remove the lamp.
5. Install the new lamp by reversing this procedure.

## Storing

---

**Note:** *If the load is to be unused or stored for any length of time, completely drain it of any coolant and cap the openings.*

1. Contain or cover the unit with plastic.
2. Store in a cool, dust free and dry area.

**Note:** *Ambient storage temperatures are not critical, however, extreme temperatures should be avoided.*

## Shipping

---

1. Completely drain the unit of all coolant.
2. Cap all openings.
3. Pack the unit securely in a sturdy wooden box or equivalent.

**Note:** *If possible, keep the original shipping carton for reshipment.*

4. Pad the container with sufficient padding to avoid shock damage.
5. Seal the container securely.

## Customer Service

---

Any maintenance or service procedure beyond the scope of those in this chapter should be referred to a qualified service center.

If the unit needs to be returned for any reason, request an Return Material Authorization (RMA) through the Bird Technologies website. All instruments returned must be shipped prepaid and to the attention of the RMA number.

### **Bird Service Center**

30303 Aurora Road  
Cleveland (Solon), Ohio 44139-2794  
Fax: (440) 248-5426  
E-mail: [bsc@birdrf.com](mailto:bsc@birdrf.com)

For the location of the Sales Office nearest you, visit our Web site at:

<http://www.birdrf.com>

## Specifications

---

<b>Power Rating</b> Models 8792	80,000 watts
RF input Impedance	50 ohms
<b>input Connector</b> Model 8792	6-1/8" EIA flanged (50 ohm)
Frequency Range	1 kHz to 800 MHz
VSWR	1.15 max. 1 kHz to 800 MHz
Modes	CW, AM, FM, SSB, TV, and certain pulse types
Input Water Temperature Range	5°C to 60°C (41°F to 140°F)
AC Power Required	115 V 60 Hz (with optional items only)
Minimum Water Flow Rate	9 GPM (34 lpm) at 5°C (41°F) 12 GPM (45.4 lpm) at 60°C (140°F)
Water Connection	3/4" standard hose thread
<b>Weight</b> Model 8792	25 lb (11.3 kg)
<b>Dimensions</b> Overall Length Model 8792 Housing Diameter Maximum Diameter (Input Flange) 8792	34 3/4" (888.7 mm) 3-1/2" (88.9 mm) 6 1/8" (156 mm)
Housing Material	Aluminum alloy and brass
Operating Position	Any
Finish	Lusterless black enamel
RF Connector & Hose Nipples	Bright Nickel Plate

## Replacement Parts List

Item	Qty.	Description	Part Number
	(1)	Water chamber assembly	8790-005
1	1	Water chamber	8790-031
2	2	Hose nipple	5-065-2
3	1	Internal O-Ring seal	5-1250
4	1	Water inlet tube	8790-032
5	1	Water inlet seal O-Ring	5-1340
6	1	Resistor cap rear seal O-Ring	5-1128
7	(1)	Resistor cap assembly	8792-003
	1	Resistor cap subassembly	8792-004
8	1	Internal resistor cap seal O-Ring	5-1251
9	1	Housing ground section	8792-007
10	1	Ground section seal O-Ring	5-1128
11	1	Third housing section	8792-002
12	1	Second housing section	8792-006
13	1	Resistor element	8792-010-1
14	1	Cone point socket hd. set screw (front and second sect.) 10-32 x 1/4 inch	standard
15	1	Outer resistor cap seal O-Ring	5-1128
17*	1	Flow switch	5-898-7
18*	1	Flow switch bushing	5-490-14
19	1	Front section housing assembly	8792-005
20	12	1/4-20 x 1 inch socket head Cap screws	standard
21	1	Flow tube	8792-009
22	1	Resistor fining	8790-0'16
23	1	Resistor fitting seal O-Ring	5-1127
24	1	Input insulator	8790-015
25	1	Insulator ring (omitted these units)	
26	1	Center conductor assembly	8790-009
27	1	3/8-16 x 3/4 inch hex head s/s Screw & lockwasher set	standard
28	1	Outer conductor assembly	8790-006
29	1	Swivel flange	4802-014
32*	1	Hose nipple	5-903
33*	1	Pipe nipple	5-489-14
34*	1	Indicator light assembly	8750-106
35*	1	Incandescent lamp 115 V	5-970-1
36*	1	Time Delay relay 115 VAC	5-1664
37*	1	Relay clamp	8630-193

\* For optional items only.

## LIMITED WARRANTY

All products manufactured by Seller are warranted to be free from defects in material and workmanship for a period of one (1) year, unless otherwise specified, from date of shipment and to conform to applicable specifications, drawings, blueprints and/or samples. Seller's sole obligation under these warranties shall be to issue credit, repair or replace any item or part thereof which is proved to be other than as warranted; no allowance shall be made for any labor charges of Buyer for replacement of parts, adjustment or repairs, or any other work, unless such charges are authorized in advance by Seller.

If Seller's products are claimed to be defective in material or workmanship or not to conform to specifications, drawings, blueprints and/or samples, Seller shall, upon prompt notice thereof, either examine the products where they are located or issue shipping instructions for return to Seller (transportation charges prepaid by Buyer). In the event any of our products are proved to be other than as warranted, transportation costs (cheapest way) to and from Seller's plant, will be borne by Seller and reimbursement or credit will be made for amounts so expended by Buyer. Every such claim for breach of these warranties shall be deemed to be waived by Buyer unless made in writing within ten days from the date of discovery of the defect.

The above warranties shall not extend to any products or parts thereof which have been subjected to any misuse or neglect, damaged by accident, rendered defective by reason of improper installation or by the performance of repairs or alterations outside of our plant, and shall not apply to any goods or parts thereof furnished by Buyer or acquired from others at Buyer's request and/or to Buyer's specifications. Routine (regularly required) calibration is not covered under this limited warranty. In addition, Seller's warranties do not extend to the failure of tubes, transistors, fuses and batteries, or to other equipment and parts manufactured by others except to the extent of the original manufacturer's warranty to Seller.

The obligations under the foregoing warranties are limited to the precise terms thereof. These warranties provide exclusive remedies, expressly in lieu of all other remedies including claims for special or consequential damages. SELLER NEITHER MAKES NOR ASSUMES ANY OTHER WARRANTY WHATSOEVER, WHETHER EXPRESS, STATUTORY, OR IMPLIED, INCLUDING WARRANTIES OF MERCHANTABILITY AND FITNESS, AND NO PERSON IS AUTHORIZED TO ASSUME FOR SELLER ANY OBLIGATION OR LIABILITY NOT STRICTLY IN ACCORDANCE WITH THE FOREGOING.