



TENULINE<sup>®</sup> ATTENUATOR  
MODEL 8327-300

OPERATION MANUAL

**WARNING**

**This unit requires the supplied vent plug be installed prior to use.  
Operating the unit without the vent plug installed WILL result in equipment damage and may  
cause personal injury.**

©COPYRIGHT 2023 BY BIRD TECHNOLOGIES, INC.  
INSTRUCTION BOOK PART NUMBER 920-8327-300 REV. D

TENULINE<sup>®</sup> IS A REGISTERED TRADEMARK OF  
BIRD ELECTRONIC CORPORATION



## Safety Precautions

---

The following are general safety precautions that are not necessarily related to any specific part or procedure, and do not necessarily appear elsewhere in this publication. These precautions must be thoroughly understood and apply to all phases of operation and maintenance.

**WARNING**

**Keep Away From Live Circuits**

**Operating Personnel must at all times observe general safety precautions. Do not replace components or make adjustments to the inside of the test equipment with the high voltage supply turned on. To avoid casualties, always remove power.**

**WARNING**

**Shock Hazard**

**Do not attempt to remove the RF transmission line while RF power is present.**

**WARNING**

**Do Not Service Or Adjust Alone**

**Under no circumstances should any person reach into an enclosure for the purpose of service or adjustment of equipment except in the presence of someone who is capable of rendering aid.**

**WARNING**

**Safety Earth Ground**

**An uninterruptible earth safety ground must be supplied from the main power source to test instruments. Grounding one conductor of a two conductor power cable is not sufficient protection. Serious injury or death can occur if this grounding is not properly supplied.**

**WARNING**

**WARNING**

**Resuscitation**

**Personnel working with or near high voltages should be familiar with modern methods of resuscitation.**

**WARNING**

**Remove Power**

**Observe general safety precautions. Do not open the instrument with the power on.**

## Safety Symbols

---

### WARNING

Warnings call attention to a procedure, which if not correctly performed, could result in personal injury.

### CAUTION

Cautions call attention to a procedure, which if not correctly performed, could result in damage to the instrument.



This symbol indicates that a shock hazard exists if the precautions in the instruction manual are not followed.



The caution symbol appears on the equipment indicating there is important information in the instruction manual regarding that particular area.



This symbol indicates that the unit radiates heat and should not be touched while hot.



This symbol indicates that the item must not be discarded but instead managed according to the collection and recycle of waste electrical and electronic equipment (WEEE) as outlined in *Directive 2002/96/EC of the European Parliament and of the Council of 27 January 2003 on waste electrical and electronic equipment (WEEE)*.

### NOTE

*Notes call attention to supplemental information.*

## Warning Statements

---

The following safety warnings appear in the text where there is danger to operating and maintenance personnel, and are repeated here for emphasis.

**WARNING**

**The vent plug must be installed at all times when the unit is in operation or cooling.  
Always check to ensure vent plug is installed prior to operation.  
Failure to do so WILL result in damage to the equipment and endanger the operator's safety.**

See pages 5, 6, 9, 13, and 15

**WARNING**

**Never attempt to disconnect the equipment from the transmission line while RF power is being applied. Leaking RF energy is a potential health hazard.**

See pages 8, 8, 9, 10, and 13

**WARNING**

**Using this Attenuator in the upper end of its power dissipation range will cause the housing to become hot! Care should be exercised in touching it.**

See pages 9

## Caution Statements

---

The following equipment cautions appear in the text and are repeated here for emphasis.

**CAUTION**

**The Attenuator is designed to be operated in the horizontal position, with mounting brackets down. Operation in any other orientation will cause insufficient cooling of the unit leading to premature failure.**

See pages 5 and 9

**CAUTION**

**Blocking should be used to support the load to avoid damage to the RF output connector.**

See page 6 and 12

**CAUTION**

**Use only Bird coolant, P/N 5-1070, to prevent damage to the load.**

See page 12

## **Safety Statements**

---

### **USAGE**

ANY USE OF THIS INSTRUMENT IN A MANNER NOT SPECIFIED BY THE MANUFACTURER MAY IMPAIR THE INSTRUMENT'S SAFETY PROTECTION.

### **USO**

EL USO DE ESTE INSTRUMENTO DE MANERA NO ESPECIFICADA POR EL FABRICANTE, PUEDE ANULAR LA PROTECCIÓN DE SEGURIDAD DEL INSTRUMENTO.

### **BENUTZUNG**

WIRD DAS GERÄT AUF ANDERE WEISE VERWENDET ALS VOM HERSTELLER BESCHRIEBEN, KANN DIE GERÄTESICHERHEIT BEEINTRÄCHTIGT WERDEN.

### **UTILISATION**

TOUTE UTILISATION DE CET INSTRUMENT QUI N'EST PAS EXPLICITEMENT PRÉVUE PAR LE FABRICANT PEUT ENDOMMAGER LE DISPOSITIF DE PROTECTION DE L'INSTRUMENT.

### **IMPIEGO**

QUALORA QUESTO STRUMENTO VENISSE UTILIZZATO IN MODO DIVERSO DA COME SPECIFICATO DAL PRODUTTORE LA PROIZIONE DI SICUREZZA POTREBBE VENIRNE COMPROMESSA.

**SERVICE**

SERVICING INSTRUCTIONS ARE FOR USE BY SERVICE - TRAINED PERSONNEL ONLY. TO AVOID DANGEROUS ELECTRIC SHOCK, DO NOT PERFORM ANY SERVICING UNLESS QUALIFIED TO DO SO.

**SERVICIO**

LAS INSTRUCCIONES DE SERVICIO SON PARA USO EXCLUSIVO DEL PERSONAL DE SERVICIO CAPACITADO. PARA EVITAR EL PELIGRO DE DESCARGAS ELÉCTRICAS, NO REALICE NINGÚN SERVICIO A MENOS QUE ESTÉ CAPACITADO PARA HACERLO.

**WARTUNG**

ANWEISUNGEN FÜR DIE WARTUNG DES GERÄTES GELTEN NUR FÜR GESCHULTES FACHPERSONAL.

ZUR VERMEIDUNG GEFÄHRLICHE, ELEKTRISCHE SCHOCKS, SIND WARTUNGSARBEITEN AUSSCHLIEßLICH VON QUALIFIZIERTEM SERVICEPERSONAL DURCHZUFÜHREN.

**ENTRETIEN**

L'EMPLOI DES INSTRUCTIONS D'ENTRETIEN DOIT ÊTRE RÉSERVÉ AU PERSONNEL FORMÉ AUX OPÉRATIONS D'ENTRETIEN. POUR PRÉVENIR UN CHOC ÉLECTRIQUE DANGEREUX, NE PAS EFFECTUER D'ENTRETIEN SI L'ON N'A PAS ÉTÉ QUALIFIÉ POUR CE FAIRE.

**ASSISTENZA TECNICA**

LE ISTRUZIONI RELATIVE ALL'ASSISTENZA SONO PREVISTE ESCLUSIVAMENTE PER IL PERSONALE OPPORTUNAMENTE ADDESTRATO. PER EVITARE PERICOLOSE SCOSSE ELETTRICHE NON EFFETTUARE ALCUNA RIPARAZIONE A MENO CHE QUALIFICATI A FARLA.

**CONNECT INTERLOCK TO TRANSMITTER/GENERATOR/AMPLIFIER BEFORE OPERATING.**

**BRANCHER LE VERROUILLAGE À L'ÉMETTEUR/GÉNÉRATEUR/AMPLIFICATEUR AVANT EMPLOI.**

**CONECTE EL INTERBLOQUEO AL TRANSMISOR/GENERADOR/AMPLIFICADOR ANTES DE LA OPERACION.**

**VOR INBETRIEBNAHME VERRIEGELUNG AM SENDER/GENERATOR/VERSTÄRKER ANSCHLIESSEN.**

**PRIMA DI METTERE IN FUNZIONE L'APPARECCHIO, COLLEGARE IL DISPOSITIVO DI BLOCCO AL TRASMETTITORE/GENERATORE/AMPLIFICATORE.**



## About This Manual

---

This instruction book covers the following models:

8327-300

## Changes to this Manual

---

We have made every effort to ensure this manual is accurate. If you discover any errors, or if you have suggestions for improving this manual, please send your comments to our Solon, Ohio factory. This manual may be periodically updated. When inquiring about updates to this manual refer to the part number and revision on the title page.

## Chapter Layout

---

**Chapter 1, Introduction, page 1** — This chapter contains introductory information about the attenuator, items supplied, and optional accessories available.

**Chapter 2, Theory of Operation, page 3** — This chapter provides information on the construction of the attenuator and the operational characteristics.

**Chapter 3, Installation, page 4** — This chapter provides information for unpacking, siting requirements, mounting, preparing the load for use, and installation of the optional thermoswitch.

**Chapter 4, Operating Instructions, page 8** — This chapter provides information for RF connections, normal operation, and abnormal operating conditions.

**Chapter 5, Maintenance, page 10** — This chapter provides troubleshooting guidance, preventive maintenance, and repair procedures. Product specifications and replacement parts are listed at the end of the maintenance section.

# TABLE OF CONTENTS

|   |            |
|---|------------|
| <b>Safety Precautions</b> .....               | <b>i</b>   |
| Safety Symbols .....                          | ii         |
| Warning Statements .....                      | iii        |
| Caution Statements .....                      | iii        |
| Safety Statements .....                       | iv         |
| <b>About This Manual</b> .....                | <b>vii</b> |
| Changes to this Manual .....                  | vii        |
| Chapter Layout .....                          | vii        |
| <b>Chapter 1 Introduction</b> .....           | <b>1</b>   |
| General Description .....                     | 1          |
| Items Supplied .....                          | 1          |
| Items Required .....                          | 1          |
| Optional Items .....                          | 1          |
| RF Connectors .....                           | 2          |
| <b>Chapter 2 Theory of Operation</b> .....    | <b>3</b>   |
| Attenuator Construction .....                 | 3          |
| Cooling .....                                 | 3          |
| Coolant Expansion .....                       | 3          |
| Heat Dissipation .....                        | 3          |
| <b>Chapter 3 Installation</b> .....           | <b>4</b>   |
| Unpacking and Inspection .....                | 4          |
| Site and Shelter Requirements .....           | 4          |
| Tools Required .....                          | 4          |
| Mounting .....                                | 5          |
| Vent Plug .....                               | 5          |
| Thermoswitch .....                            | 6          |
| Thermoswitch Installation .....               | 6          |
| Thermoswitch Wiring Installation .....        | 7          |
| <b>Chapter 4 Operating Instructions</b> ..... | <b>8</b>   |
| Initial Adjustments .....                     | 8          |
| RF Connection .....                           | 8          |
| Normal Operation .....                        | 9          |
| Operation Under Abnormal Conditions .....     | 9          |
| Shutdown .....                                | 9          |
| Emergency Shutdown .....                      | 9          |

---

|                                      |           |
|--------------------------------------|-----------|
| <b>Chapter 5 Maintenance</b> .....   | <b>10</b> |
| Troubleshooting .....                | 10        |
| Routine Maintenance .....            | 11        |
| Inspect the Attenuator .....         | 11        |
| Clean the Attenuator .....           | 11        |
| Inspect the Coolant .....            | 12        |
| RF Assembly Resistance Test .....    | 13        |
| Repair .....                         | 14        |
| Replace RF Connector .....           | 14        |
| Replace Coolant .....                | 14        |
| Replace RF Load Resistor .....       | 16        |
| Thermoswitch .....                   | 16        |
| Additional Repairs .....             | 16        |
| Shipping the Attenuator .....        | 16        |
| RF Section Assembly .....            | 16        |
| Complete Unit .....                  | 16        |
| Storing the Attenuator .....         | 16        |
| Customer Service .....               | 17        |
| Specifications .....                 | 18        |
| Replacement Parts .....              | 19        |
| Available “QC” Type Connectors ..... | 19        |
| <b>Limited Warranty</b> .....        | <b>20</b> |

## General Description

---

The Model 8727-300 Attenuator is a low-reflection resistance network for use in reducing RF power in 50 ohm transmission lines by known and controlled amounts.

The unit may be used for isolation of power sources up to 1000 W and for low level monitoring. This attenuator is useful for lowering a high input RF power to a level suitable for feeding into an oscilloscope, frequency counter or similar device. The low power value obtained at the output of the attenuator can easily be read on an oscilloscope or terminated in a small RF load resistor.

It is a self-contained instrument intended to be fully cooled by natural convection in normal ambient air with a power input of 1000 W and does not require any external source of power or utilities for cooling purposes.

A system of resistive film-on-ceramic cylindrical resistors immersed in a dielectric coolant constitutes the RF section assembly. The coolant carries the heat generated in the various resistor elements to the walls of the coolant housing. The housing is encased in a set of radiating fins which are attached to its outer surface. The rhomboid shaped cooling fins spaced evenly along its length dissipate the heat of the coolant into the surrounding air for the most efficient cooling. See [Figure 1 on page 2](#).

The front and rear panels of the unit have mounting flanges. These flanges act as supports for optional fixed mount. Mounting holes are provided for this purpose. Mounting of this unit is described in Chapter 3 - Installation.

## Items Supplied

---

The following items are supplied with the Model 8327-300:

- LC Female connector - input end
- N Female connector - output end
- Instruction Manual

## Items Required

---

The following items are required to put the Model 8327-300 into service.

- Multimeter
- Screwdrivers
- Matching connectors on the coaxial transmission line

## Optional Items

---

The following items are available as optional equipment.

- Overload thermostwitch, P/N 2450-056 for protection against burnout.
- Quick-Change (QC) connectors for convenient and easy interchange with other "AN" type QC connectors. Refer to the list in the Maintenance Chapter.

## RF Connectors

The 8327-300 Attenuators are equipped with a Bird Quick-Change (QC) connectors.

LC Female connector for the input and a female N type connector for the output are normally supplied but they may be conveniently and easily interchanged with other Bird QC connectors. See ["Available "QC" Type Connectors" on page 19](#) for a list of available connectors. See ["Replace RF Connector" on page 14](#) for replacement instructions.

**Figure 1 Outline Drawing**

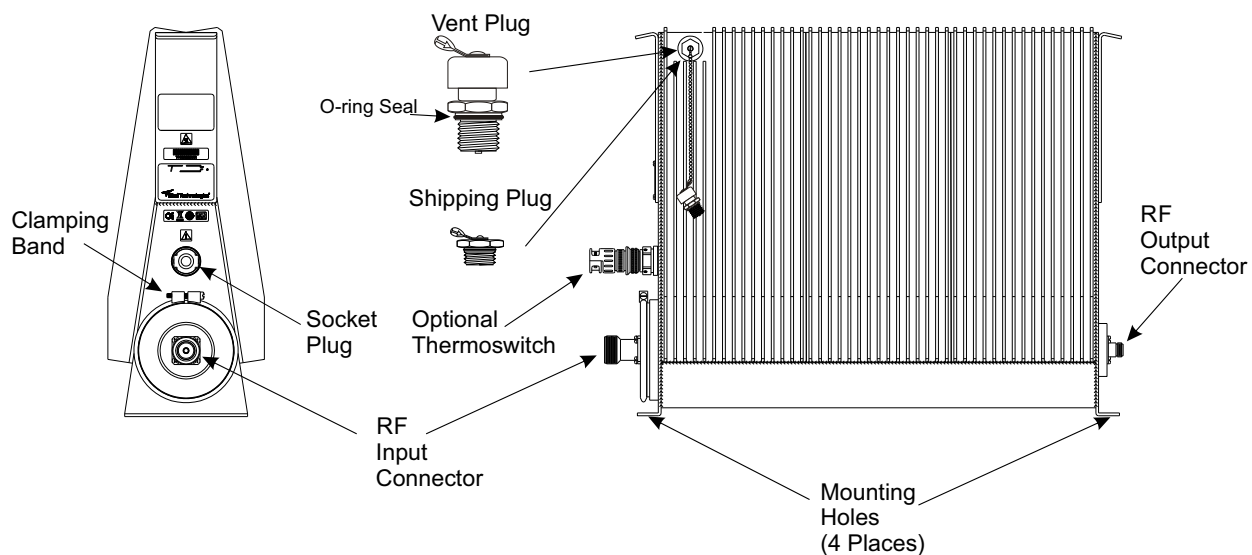

The Model 8327-300 may be used for isolation of power sources up to 1000 W and for low level monitoring. The low power value obtained at the output of the attenuator can easily be read on an oscilloscope or terminated in a small RF load resistor.

### **Attenuator Construction**

---

The Model 8327-300 Attenuator is a symmetrical “T” pad, with the power distribution on the legs being different. Therefore, the value of the resistance on each leg is different according to the power it is to absorb. On the input resistor element, a proportionately larger resistor is of course required for its much greater power dissipation. A “T” configuration is used to provide equal input and output impedance’s for the 50 ohm transmission line attenuation.

The input resistor is joined by the “T” leg joint in an exponentially tapered housing to provide a linear reduction in surge impedance of 50 ohms. This arrangement produces a uniform and practically reflectionless attenuation characteristic over the stated frequencies of the attenuator.

This system of carbon-film-on-ceramic cylindrical resistors immersed in a dielectric coolant constitutes the RF section assembly. The cooling liquid and the tapered input resistor housing provide the proper electrical characteristics of the coaxial line termination.

### **Cooling**

---

The dielectric coolant is carefully chosen for its desirable dielectric properties, to which the diameters of the resistors and housings are matched, and for its high thermal stability characteristics.

### **Coolant Expansion**

---

When power is applied to the attenuator, the coolant expands, as the air in the coolant housing is compressed it is allowed to escape through the vent plug located near the top and front face of the unit.

### **Heat Dissipation**

---

Heat Dissipation is accomplished by convection, the coolant carries the heat generated in the various resistor elements to the walls of the coolant housing. The housing is encased in a set of radiating fins which are attached to its outer surface. These radiating fin surfaces dissipate the heat of the coolant into the surrounding air.

## Unpacking and Inspection

---

1. Carefully inspect shipping container for signs of damage.
  - If the shipping container is damaged, do not unpack the unit. Immediately notify the shipping carrier and Bird Technologies.
  - If the shipping container is not damaged, unpack the unit. Save shipping materials for repackaging.
2. Inspect unit for visual signs of damage.

**NOTE**

*If there is damage, immediately notify the shipping carrier and Bird Technologies.*

## Site and Shelter Requirements

---

The unit should be operated in a dry, dust and vibration free environment.

The ambient temperature range should remain between -40°C and +45°C (-40°F and +113°F) for proper operation.

Allow at least 12" (305 mm) of clearance around the unit to permit an unimpeded access of convection air currents for adequate heat dissipation.

Place the attenuator as close as possible to the transmitting equipment, to permit the shortest possible cable length.

## Tools Required

---

The following tools and supplies will be required to prepare the unit for use.

- Wrenches
- Screwdrivers
- Bolt and nut sets or lag screws (for mounting)

These tools and supplies are required for optional thermoswitch installation

- 9/16 Hex wrench
- Pipe sealing compound (Loctite 567, or equivalent)
- Soldering Iron and solder
- Torque Wrench

## Mounting

---

**CAUTION**

**The Attenuator is designed to be operated in the horizontal position, with mounting brackets down. Operation in any other orientation will cause insufficient cooling of the unit leading to premature failure.**

The attenuator may stand free or may be secured to a bench or any convenient flat surface. The front and rear face plates are made of heavier gauge material bent outward 90° at the bottom to form mounting flanges. At each corner of these flanges is a 3/8 inch x 15/32 inch elongated hole for use with suitable fasteners up to 3/8 inch. The holes are arranged in a 20-23/32 inch x 4-1/2 inch rectangle (526.3 x 114.3 mm). The front and rear face plates of the attenuator are also bent over on the top to form convenient carrying handles.

The following instructions are for mounting the unit to a suitable surface.

1. Place the unit on a flat surface.
2. Insert the fasteners, up to 3/8 inch, through the bench and the holes.
3. Secure the bolts with nuts and lock washers.

## Vent Plug

---

**WARNING**

**The vent plug must be installed at all times when the unit is in operation or cooling. Always check to ensure vent plug is installed prior to operation. Failure to do so WILL result in damage to the equipment and endanger the operator's safety.**

Before placing the attenuator into service, the solid shipping plug, P/N 2450-049, must be removed and replaced by the spring loaded vent plug, P/N 2450-094. The two plugs are linked together by a short length of bead chain.

1. Locate the vent hole for the plug, located at the top left hand side near the front.  
See [Figure 1 on page 2](#).
2. Remove the shipping plug.
3. Verify the O-Ring is installed on the vent plug.
4. Install the vent plug.
5. Retain the shipping plug for use in transporting the attenuator.  
The shipping plug should be placed back in the vent hole whenever the attenuator is to be shipped. Take care not to lose the O-Ring seal.



## Thermoswitch

As an option, the attenuator may be provided with a thermoswitch assembly, P/N 2450-056. The thermoswitch is used as an interlock switch to disable transmitter power if the coolant temperature exceeds a preset temperature, thus preventing possible damage from accidental power overloading from the transmitter or equipment malfunction.

The thermoswitch is normally closed and opens at a maximum safe temperature. Since the thermoswitch is connected in series with the transmitter interlock, it cuts off transmitter power if the coolant temperature exceeds this value. The assembly consists of:

- Thermoswitch body - P/N 2450-040
- Coupling Jack - P/N 2450-018

## Thermoswitch Installation

1. Remove the vent plug.
2. Verify the O-Ring is installed on the shipping plug.
3. Install the shipping plug.

### CAUTION

**Blocking should be used to support the load to avoid damage to the RF output connector.**

4. Stand the unit on its back end with the RF input connector end up.

### NOTE

*In this position there is no danger of the coolant pouring out through the socket plug hole.*

5. Remove the socket plug located just above the input connector on the front face of the radiator using a 9/16 hex wrench. See [Figure 1 on page 2](#).

### NOTE

***Do not contaminate the coolant with pipe sealing compound.***

6. Sparingly apply pipe sealing compound to the external threads, only.
7. Install the thermoswitch in place of the plug. Torque to 40 +/-2 ft-lbs.
8. Lower the attenuator back onto its feet.
9. Check the unit for coolant leaks.

### WARNING

**The vent plug must be used at all times when the unit is in operation or cooling.**

**Always check to ensure vent plug is installed prior to operation.**

**Failure to do so WILL result in damage to the equipment and endanger the operator's safety.**

10. Remove the shipping plug.
11. Verify the O-Ring is installed on the vent plug.
12. Install the vent plug.

## Thermoswitch Wiring Installation

1. Unscrew the larger knurled ring-nut (A) at the lower end of the coupling jack assembly.
2. Pull the large knurled ring-nut (A) off the thermoswitch jack (B).
3. Unscrew the small knurled cover fitting (C) from the base plug (D) of the connector to release the base.
4. Thread the interlock wires through the clamp (E) with the washers (F) inside and with its threaded fitting in place.
5. Service the interlock wire with short tips, use spaghetti sleeves over the wire ends if necessary.
6. Securely solder the interlock leads to the lugs (G) of the connector base.

**NOTE**

*The ring-nut (A) must be in place over the base plug (D) with the knurled end facing out.*

7. Screw on the cover ring (C) first.
8. Fasten the cable clamp (E) in place.
9. Tighten the two yoke screws (H) on the cable.
10. Push the plug back onto the thermoswitch.
11. Tighten the knurled ring-nut (A).

**NOTE**

*Do not attempt to operate the equipment without the interlock attached.*

12. Connect the Thermoswitch wiring to the transmitter's interlock.

**Figure 2 Thermoswitch Assembly**

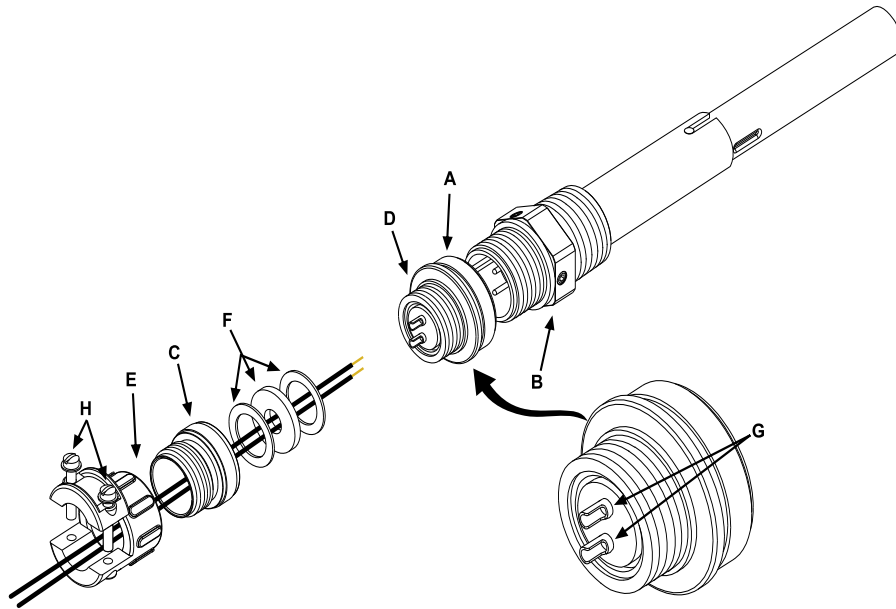

There are no operating controls for the Model 8327-300 Attenuator. Read and become familiar with the following instructions before operating the unit. If your attenuator is equipped with a thermoswitch, refer to the instructions for connection to the interlock.

## Initial Adjustments

---

### WARNING

**Never attempt to disconnect the equipment from the transmission line while RF power is being applied. Leaking RF energy is a potential health hazard.**

Before connection of the attenuator, perform the following steps.

1. Wipe all connectors and insulator surfaces on the transmission line face with a clean soft cloth.
2. Check the RF input connector for signs of wear, damage, or dirt.
3. Clean the connector if necessary. Use a self-drying, non-residue forming contact cleaner on the interior portions of the connector.
4. Check the input resistance of the attenuator. Refer to ["RF Assembly Resistance Test" on page 13](#).

## RF Connection

---

### WARNING

**Never attempt to disconnect the equipment from the transmission line while RF power is being applied. Leaking RF energy is a potential health hazard.**

The front or input end of the attenuator is identified by the four inch (102 mm) diameter die-cast aluminum disc on which the connector is mounted. The rear face of the unit has OUTPUT stenciled above the connector. *Do not couple the attenuator backwards to the direction of power flow. Destruction of the output resistor will result.*

1. Connect the attenuator input to the transmitter's power output. Use 50 ohm coaxial cable.
2. Connect the attenuator output to a suitable load with 50 ohm coaxial cable (RG-8A/U, RG-9/U, RG-213/U or equivalent) equipped with connectors which mate with the RF output connector of the attenuator.
3. Follow the transmitter manufacturer's instructions.

### NOTE

***If the attenuator is to be operated at both maximum power and frequency values, use a Male LC connector with a suitable cable (RG-218/U or RG-220/U) on the input and Male N connector with appropriate cable or load on the output. These connect to the RF fittings normally supplied.***

Before applying any RF power to the attenuator, be certain to check that the vent plug is in place in the vent hole. Refer ["Vent Plug" on page 5](#).

## Normal Operation

---

**WARNING**

The vent plug must be installed at all times when the unit is in operation or cooling.  
Always check to ensure vent plug is installed prior to operation.  
Failure to do so WILL result in damage to the equipment and endanger the operator's safety.

**WARNING**

Using this Attenuator in the upper end of its power dissipation range will cause the housing to become hot! Care should be exercised in touching it.

**CAUTION**

The Attenuator is designed to be operated in the horizontal position, with mounting brackets down.  
Operation in any other orientation will cause insufficient cooling of the unit leading to premature failure

Because the Model 8327-300 Attenuator is a passive device and has no indicators or controls, it requires no operating procedures or surveillance when the performance limits are not exceeded. It should function faultlessly, absorbing and converting the excess RF energy into heat indefinitely, if it is properly maintained and not subjected to an overload.

## Operation Under Abnormal Conditions

---

The Model 8327-300 Attenuator is not intended or recommended for outdoor use. The Attenuator may be subjected to moderate overloads for limited periods of time without overheating. However, this should be done cautiously, and it is strongly recommended that if such a use is contemplated, the attenuator should be equipped with a thermoswitch, P/N 2450-056. When interlocked with the power line to the source of RF energy, the thermoswitch becomes a fail safe device to guard the attenuator against the dangers of overheating.

## Shutdown

---

**WARNING**

Never attempt to disconnect the equipment from the transmission line while RF power is being applied. Leaking RF energy is a potential health hazard.

Turn off RF power at the source.

This attenuator, being a passive device, cannot be shut off. The source of RF energy must be cut off instead.

## Emergency Shutdown

---

Turn off RF power at its source.

If equipped with a thermoswitch interlock, and it is properly connected, RF power will be automatically turned off when the coolant temperature reaches an unsafe level.

This chapter contains operator maintenance instructions, troubleshooting, and parts information.

**WARNING**

**Never attempt to disconnect RF equipment from the transmission line while RF power is being applied. Leaking RF energy is a potential health hazard.**

## Troubleshooting

---

The table below contains troubleshooting information for problems which can occur during normal operation. This manual cannot list all malfunctions that may occur, or their corrective actions. If a problem is not listed or is not corrected by the listed actions, notify a qualified service center.

| <b>Problem</b>            | <b>Possible Cause</b>                                  | <b>Correction</b>   |
|---------------------------|--|---|
| Leaking coolant           | Loose clamping band                                    | Tighten the clamping band   |
|                           | Defective or improperly installed front (input) O-ring | Replace the O-ring<br>(See " <a href="#">Replace Coolant</a> " on page 14)                                    |
|                           | Defective or improperly installed rear (output) O-ring | Replace the O-ring<br>(See " <a href="#">Replace Coolant</a> " on page 14)                                    |
| High or low DC resistance | Loose RF input connector                               | Tighten connector   |
|                           | Faulty RF input connector                              | Replace connector (See " <a href="#">Replace RF Connector</a> " on page 14)                                   |
|                           | Faulty RF Section assembly                             | Replace the RF Section assembly<br>(See " <a href="#">Replace RF Load Resistor</a> " on page 16)              |
| Overheating radiator      | RF power too high                                      | Lower RF power (" <a href="#">Specifications</a> " on page 18 for maximum RF power)                           |
|                           | Coolant level too low                                  | Check the coolant level. Add coolant if necessary<br>(See " <a href="#">Inspect the Coolant</a> " on page 12) |
|                           | Faulty RF Section assembly                             | Replace the RF Section assembly<br>(See " <a href="#">Replace RF Load Resistor</a> " on page 16)              |

## Routine Maintenance

Figure 3 shows the location of components which may be referred to in this section.

**Figure 3 Maintenance and Repair Locations**

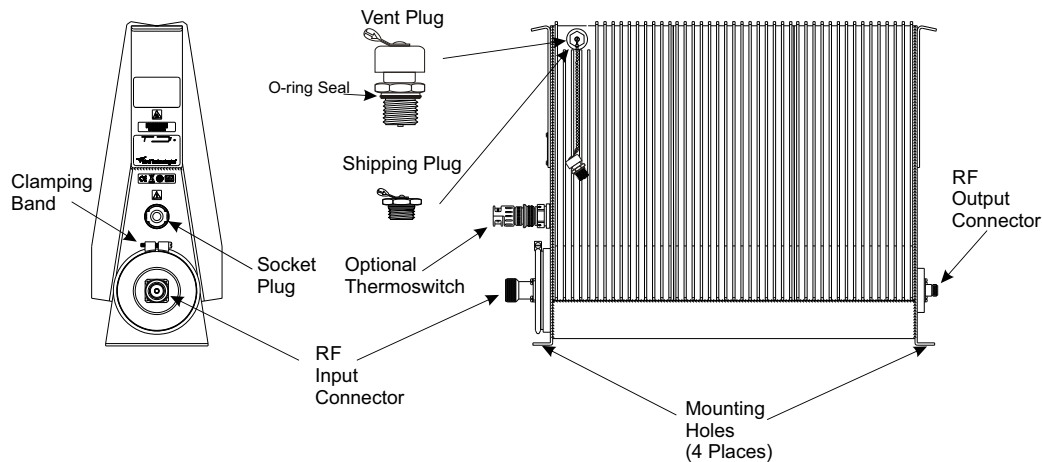

## Inspect the Attenuator

- Inspect the unit every six months.
  - a. Check for coolant leakage around the clamping band
  - b. Check for coolant leakage around the thermostick (if equipped).
  - c. Check the unit for corrosion.

## Clean the Attenuator

The most important cleaning task is to remove accumulations of dust and lint from the radiator fins. An extensive collection of dust and lint on the cooling fins will interfere with the efficient dissipation of heat. When dirt and dust have accumulated in the radiator fin spaces it should be cleaned.

- Clean the cooling fins.

**NOTE**

*Excessive dust on the cooling fins will interfere with heat dissipation.*

Preparation:

- Material: Lint-free cleaning cloth
- Mild detergent

To clean the unit follow the instructions below.

1. Gently remove loose dirt and grime using a soft clean cloth dampened with a mild warm solution of detergent and water.
2. Check the condition of the RF coaxial connector. If it needs cleaning, clean the connector with a self-drying contact cleaner, that leaves no residue on the inaccessible portions.

## Inspect the Coolant

The level of the dielectric coolant should remain constant in the unit after prolonged usage under normal operating conditions. As shipped, the coolant is at a factory determined level, and should be about 3-1/4 inches (82.5 mm) below the surface of the thermoswitch hole, with the unit in a vertical position. However, loss of up to 10% of the full tank capacity should not impair the operating efficiency of the attenuator.

Coolant lifetime will vary greatly depending on the operating temperature.

- **Heavy Use (full RF power for long times, high ambient temperature):**  
Inspect the coolant every 500 hours.
- **Light Use (fraction of full power, low ambient temperature):**  
Inspect coolant every 2,000 hours.

To inspect the coolant:

1. Remove the vent plug.
2. Verify the O-Ring is installed on the shipping plug.
3. Install the shipping plug.

### CAUTION

**Blocking should be used to support the load to avoid damage to the output RF connector.  
The output RF connector extends from the back of the load.**

4. Supporting the unit to prevent damage to the output RF connector, stand the unit on its back with the input RF connector end up.
5. Remove the socket plug (or Thermoswitch, if installed) located just above the input RF connector on the front face of the radiator using a 9/16 hex wrench. See [Figure 3 on page 11](#).
6. Use a dip stick to test the oil.
  - The coolant should be clear, with a faint yellow tinge, and have a slightly sweet smell.
  - If coolant is black with a burnt or acrid smell, replace the coolant, see ["Replace Coolant" on page 14](#).
7. With the load still on end, the coolant level should be 3-1/4 inches (82.5 mm) below the top surface of the thermoswitch hole, at ambient temperature.

### CAUTION

**Use only Bird coolant, P/N 5-1070, to prevent damage to the load.**

### NOTE

***Do not overfill the unit beyond the recommended level.***

8. If required, add coolant through the pipe plug hole (thermoswitch hole) until it reaches the proper level, about 3-1/4 inches (82.5 mm) below the surface of the hole.
9. Sparingly coat the pipe plug or thermoswitch threads with pipe sealant.

### NOTE

***Do not contaminate the coolant.***

10. Screw the pipe plug or thermoswitch back in place carefully to avoid stripping the aluminum threads of the plug hole.
11. Lower the attenuator back onto its feet.
12. Check all seals for signs of leaks.

**WARNING**

**The vent plug must be installed at all times when the unit is in operation or cooling.**

**Always check to ensure vent plug is installed prior to operation.**

**Failure to do so WILL result in damage to the equipment and endanger the operator's safety.**

13. Remove the shipping plug.
14. Verify the O-Ring is installed on the vent plug.
15. Install the vent plug.

## RF Assembly Resistance Test

---

**NOTE**

***These tests are by no means a necessity to the operation of the attenuator but merely guidelines for the users information.***

Accurate measurement of the DC resistance between the input to ground, output to ground, and input to output will provide a good check of the condition of the attenuator.

Checking the DC resistance is simply used to measure a change in the resistance over time. Tracking the DC resistance should start *before* the unit is first put into service. Perform the following steps and record the value for future comparison. Resistance measurements should be taken periodically according to use.

Preparation:

- Tools: Common hand tools.
- Ohmmeter with an accuracy of  $\pm 1\%$  at 50 ohms (or use a resistance bridge).
- Use low resistance leads, preferably a short piece of 50 ohm coaxial cable fitted with an appropriate connector or alligator clips.
- Temperature of the attenuator should be stabilized between 20°C to 25°C (68°F to 77°F).

## DC Resistance Measurement

**WARNING**

**Never attempt to connect or disconnect RF equipment from the transmission line while RF power is being applied. Leaking RF energy is a potential health hazard.**

**NOTE**

***It is recommended that this resistance check be performed each time the attenuator is to be used.***

1. Turn off RF power before making any disconnections.
2. Disconnect the RF coaxial line.
3. Take the following measurements:
  - a. Connect the multimeter test leads across the center and outer conductor of the attenuators INPUT connector. See [Figure 4](#).  
Result should be  $50 \pm 2$  Ohms
  - b. Connect the multimeter test leads across the center and outer conductor of the Attenuators OUTPUT connector.  
Result should be  $50 \pm 2$  Ohms
  - c. Connect the multimeter test leads across the INPUT center conductor and the OUTPUT center conductor.  
Result should be  $93.7 \pm 2$  Ohms



- Record the value of the resistance *before* the attenuator is put into service. Compare subsequent values with the latest reading. If the values vary more than 2 ohms this could be an indication of a failing Attenuator.

**Figure 4 Measuring DC Resistance**

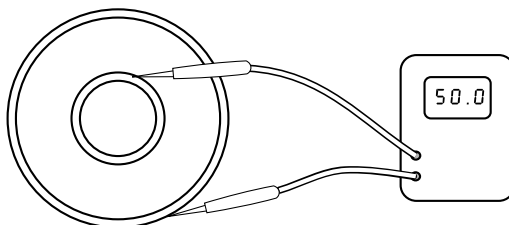

## Repair

### Replace RF Connector

Tool required:

- Screwdriver

The following paragraphs outline the component removal and replacement procedure.

The connector is a Quick-Change (QC) design which permits easy interchange with the use of only a screwdriver. This process does not interfere with the essential coaxial continuity of the attenuator RF input, out put, or the coolant oil seals. For replacement, proceed as follows:

- Remove and retain the four screws from the corners of the RF connector.
- Pull the connector straight out of its socket.
- Insert the new connector into the mating connector. Be sure the projecting center pin on the connector is properly engaged and seated in the mating socket, then push it in firmly.
- Install the four screws that were previously removed.

### Replace Coolant

To replace all of the coolant use the following procedure:

- Remove the rear RF (output) connector. See "[Replace RF Connector](#)" on page 14.
- Remove the vent plug.
- Verify the O-Ring is installed on the shipping plug.
- Install the shipping plug.
- Raise the unit, carefully, by its front handle and foot until it is tipped up on its back.
- Position the load on the bench top so that the entire rear connector assembly, minus the connector, projects over the edge of the bench.
- Brace the unit vertically in this position so that it will not topple over.
- Place a clean container for liquid just under the rear connector assembly to receive the coolant.

#### NOTE

***The volume of the oil is 2.9 gallons (11 liters), so the container must be at least a three gallon size, and preferably five gallons.***

- Remove the clamping band from around the front (input) connector assembly by loosening the 10-32 holding screw sufficiently to slip the band off.
- Carefully work the RF section assembly loose and lift it straight out of the resistor tank.

**NOTE**

***There will be some initial resistance as the O-Ring seal around the rear connector assembly comes loose from the housing.***

11. As the RF section comes out of the rear connector assembly, the coolant will start to pour into the container. Work the RF section loose slowly, so that the coolant doesn't splash coming out.
12. Let the coolant drip for a few minutes to get as much as possible out of the radiator tank.

**NOTE**

***As the RF section is raised out of the radiator tank some coolant will be trapped in the rear end cylinder.***

13. Turn the section over carefully to empty it out.

**NOTE**

***An alternate, but much slower, method of draining the radiator would be to siphon the coolant out of the thermostitch hole.***

14. Discard the contaminated coolant collected in the container.
15. Replace the RF section assembly.

**NOTE**

***Make sure that it is smoothly and firmly seated in the rear connector assembly.***

16. Replace the clamping band on the front connector plate assembly and tighten the screw.
17. Add clean coolant to the unit.

**NOTE**

***Fill the unit until the level is about 3-1/4 inches below the thermostitch hole.***

18. Sparingly coat the pipe plug or thermostitch threads with pipe sealant.

**NOTE**

***Do not contaminate the coolant.***

19. Screw the pipe plug or thermostitch back in place carefully to avoid stripping the aluminum threads of the plug hole.
20. Lower the attenuator back onto its feet.
21. Check all seals for signs of leaks.

**WARNING**

**The vent plug must be installed at all times when the unit is in operation or cooling.**

**Always check to ensure vent plug is installed prior to operation.**

**Failure to do so WILL result in damage to the equipment and endanger the operator's safety.**

22. Remove the shipping plug.
23. Verify the O-Ring is installed on the vent plug.
24. Install the vent plug.

## Replace RF Load Resistor

---

To replace the load resistor follow the same procedure as in the Replacing Coolant section.

However, inspect the O-Ring seals. Do not reuse the O-Rings if they are no longer soft and pliable or shows signs of cracks. If the coolant removed is not contaminated, it may be reused in the radiator tank with additional new coolant as required.

The RF section is not field repairable and further disassembly should not be attempted. Return the entire RF assembly to the factory for repair or replacement.

## Thermoswitch

---

To replace the Thermoswitch, refer to "[Thermoswitch Installation](#)" on page 6 and "[Thermoswitch Wiring Installation](#)" on page 7.

## Additional Repairs

---

Any maintenance or service procedure beyond the scope of those provided in this section should be referred to a qualified service center.

## Shipping the Attenuator

---

### RF Section Assembly

---

1. Wrap the RF section assembly with sufficient padding to avoid damage in shipping and tape securely.
2. Place the wrapped RF section in a cardboard carton and pad or brace it to prevent shifting.

### Complete Unit

---

Should you need to return the Attenuator, the unit may be shipped with its dielectric coolant; however, do not ship the unit with its dielectric coolant if the unit has developed a leak. Drain the coolant first.

1. Remove the vent plug.
2. Verify the O-Ring is installed on the shipping plug.
3. Install the shipping plug.

**NOTE**

*With the shipping plug installed, it is not necessary to empty out the coolant.*

4. Place the attenuator in a wooden crate or other substantial shipping container.
5. Pack and brace the container securely to prevent damage in shipping.

**NOTE**

*All instruments returned for service must be shipped prepaid and to the attention of the Customer Service Group. See "[Customer Service](#)" on page 17.*

## Storing the Attenuator

---

1. Cover the equipment to keep out dust and dirt.
2. Store the unit in a dust-free, dry environment with an ambient temperature range of -40°C to -45°C (-40°F to +113°F) operational range of the device.

## Customer Service

---

Any maintenance or service procedure beyond the scope of those in this chapter should be referred to a qualified service center.

If the unit needs to be returned for any reason, request an Return Material Authorization (RMA) through the Bird Technologies website. All instruments returned must be shipped prepaid and to the attention of the RMA number.

### **Bird Service Center**

30303 Aurora Road  
Cleveland (Solon), Ohio 44139-2794  
Fax: (440) 248-5426  
E-mail: [bsc@birdrf.com](mailto:bsc@birdrf.com)

For the location of the Sales Office nearest you, visit our Web site at:

<http://www.birdrf.com>

## Specifications

|                              |   |
|------------------------------|---|
| Frequency Range              | DC – 500 MHz  |
| Input Power Rating           | 1000 Watts  |
| Impedance, Nominal           | 50 ohms   |
| Nominal Attenuation          | 30 dB $\pm$ 0.5 dB  |
| Calibration Accuracy         | $\pm$ 0.2 dB  |
| Calibration Frequencies      | 30, 100, 200, 300, 400, 500 MHz   |
| Power Sensitivity Correction | -1 x 10 <sup>-6</sup> dB/Watt/MHz $\pm$ 0.2 dB  |
| VSWR                         |   |
| Input                        | 1.10 Max  |
| Output                       | 1.15 Max  |
| Connectors                   |   |
| Input                        | Female LC, "QC" Type  |
| Output                       | Female N, "QC" Type   |
| Operating Position           | Horizontal only – vent plug up  |
| Ambient Temperature          | -40 to +45 °C (-40 to +113 °F)  |
| Cooling Method               | Oil dielectric and convection currents  |
| Dimensions                   | 23-15/32" L x 7-1/8" W x 17-3/16" H<br>(596 x 181 x 437 mm)   |
| Mounting Dimensions          | 20-23/32" x 4-1/2" rectangle<br>(526.3 x 114.3 mm)  |
| Weight, Nominal              | 57 lb. 8 oz. (26 kg)  |
| Finish                       | Gray Powder Coat  |
| Safety                       | Meets requirements of EN 61010-1:2010 - Safety requirements for electrical equipment for measurement, control, and laboratory use - Part 1: General requirements, which is in accordance with directives 2014/35/EU and 2011/65/EU. |

## Replacement Parts

| Description  | Qty                     | Part Number  |
|--|-------------------------|--|
| RF section assembly  | 1                       | 8327-302   |
| Radiator Assembly  | 1                       | 8329-307   |
| Dielectric Coolant   | 2.9 Gal.<br>(11 liters) | 5-030-3<br>(1 Gallon Container)                    |
| QC Connector   | 3                       | See <a href="#">Available "QC" Type Connectors</a> |
| Clamp Band Assembly (includes screws)  | 1                       | 2430-055   |
| Input O-Ring Seal  | 1                       | 8110-039   |
| Output O-Ring Seal   | 1                       | 5-176  |
| Vent & Shipping Plug Kit<br>(includes 1 each: vent & shipping plugs, o-ring,<br>chain assembly, and screw) |                         | RPK8000-1  |
| Vent Plug  | 1                       | 2450-094   |
| Shipping Plug  | 1                       | 2450-049   |
| Chain Assembly   | 1                       | 8180-094   |
| O-Ring<br>(Used for Vent/Shipping Plug)  | 1                       | 5-504  |
| Thermo Switch Plug   |                         | 5020-103   |
| Thermoswitch Kit<br>Consisting of:   |                         | 2450-056   |
| Connector Assembly   |                         | 2450-018   |
| Thermoswitch Assembly  |                         | 2450-040   |

## Available "QC" Type Connectors

| Connector              | Part Number |
|------------------------|-------------|
| N-Female <sup>1</sup>  | 4240-062    |
| N-Male                 | 4240-063    |
| HN-Female              | 4240-268    |
| HN-Male                | 4240-278    |
| LC-Female <sup>1</sup> | 4240-031    |
| LC-Male                | 4240-025    |
| LT-Female              | 4240-018    |
| LT-Male                | 4240-012    |
| C-Female               | 4240-100    |
| C-Male                 | 4240-110    |
| UHF-Female             | 4240-050    |
| UHF-Male               | 4240-179    |
| 7/8" EIA               | 4240-002    |

1 Normally supplied on the 8327-300

## Limited Warranty

All products manufactured by Seller are warranted to be free from defects in material and workmanship for a period of one (1) year, unless otherwise specified, from date of shipment and to conform to applicable specifications, drawings, blueprints and/or samples. Seller's sole obligation under these warranties shall be to issue credit, repair or replace any item or part thereof which is proved to be other than as warranted; no allowance shall be made for any labor charges of Buyer for replacement of parts, adjustment or repairs, or any other work, unless such charges are authorized in advance by Seller.

If Seller's products are claimed to be defective in material or workmanship or not to conform to specifications, drawings, blueprints and/or samples, Seller shall, upon prompt notice thereof, either examine the products where they are located or issue shipping instructions for return to Seller (transportation charges prepaid by Buyer). In the event any of our products are proved to be other than as warranted, transportation costs (cheapest way) to and from Seller's plant, will be borne by Seller and reimbursement or credit will be made for amounts so expended by Buyer. Every such claim for breach of these warranties shall be deemed to be waived by Buyer unless made in writing within ten days from the date of discovery of the defect.

The above warranties shall not extend to any products or parts thereof which have been subjected to any misuse or neglect, damaged by accident, rendered defective by reason of improper installation or by the performance of repairs or alterations outside of our plant, and shall not apply to any goods or parts thereof furnished by Buyer or acquired from others at Buyer's request and/or to Buyer's specifications. Routine (regularly required) calibration is not covered under this limited warranty. In addition, Seller's warranties do not extend to the failure of tubes, transistors, fuses and batteries, or to other equipment and parts manufactured by others except to the extent of the original manufacturer's warranty to Seller.

The obligations under the foregoing warranties are limited to the precise terms thereof. These warranties provide exclusive remedies, expressly in lieu of all other remedies including claims for special or consequential damages. SELLER NEITHER MAKES NOR ASSUMES ANY OTHER WARRANTY WHATSOEVER, WHETHER EXPRESS, STATUTORY, OR IMPLIED, INCLUDING WARRANTIES OF MERCHANTABILITY AND FITNESS, AND NO PERSON IS AUTHORIZED TO ASSUME FOR SELLER ANY OBLIGATION OR LIABILITY NOT STRICTLY IN ACCORDANCE WITH THE FOREGOING.

