



HIGH POWER
SEMICONDUCTOR
CAL CART

OPERATION MANUAL

©COPYRIGHT 2016 BY BIRD ELECTRONIC CORPORATION
INSTRUCTION BOOK PART NUMBER 920-HPCC REV. J

THRULINE® AND TERMALINE® ARE A REGISTERED TRADEMARKS
OF BIRD ELECTRONIC CORPORATION

Safety Precautions

The following are general safety precautions that are not necessarily related to any specific part or procedure, and do not necessarily appear elsewhere in this publication. These precautions must be thoroughly understood and apply to all phases of operation and maintenance.

WARNING

Keep Away From Live Circuits

Operating Personnel must at all times observe general safety precautions. Do not replace components or make adjustments to the inside of the test equipment with the high voltage supply turned on. To avoid casualties, always remove power.

WARNING

Shock Hazard

Do not attempt to remove the RF transmission line while RF power is present.

WARNING

Do Not Service Or Adjust Alone

Under no circumstances should any person reach into an enclosure for the purpose of service or adjustment of equipment except in the presence of someone who is capable of rendering aid.

WARNING

Safety Earth Ground

An uninterruptible earth safety ground must be supplied from the main power source to test instruments. Grounding one conductor of a two conductor power cable is not sufficient protection. Serious injury or death can occur if this grounding is not properly supplied.

WARNING

Resuscitation

Personnel working with or near high voltages should be familiar with modern methods of resuscitation.

WARNING

Remove Power

Observe general safety precautions. Do not open the instrument with the power on.



Safety Symbols

WARNING

Warning notes call attention to a procedure, which if not correctly performed, could result in personal injury.

CAUTION

Caution notes call attention to a procedure, which if not correctly performed, could result in damage to the instrument.

	<p>This symbol indicates that a shock hazard exists if the precautions in the instruction manual are not followed.</p>
	<p>The caution symbol appears on the equipment indicating there is important information in the instruction manual regarding that particular area.</p>
	<p>This symbol indicates that the unit radiates heat and should not be touched while hot.</p>

Note: *Calls attention to supplemental information.*

Warning Statements

The following safety warnings appear in the text where there is danger to operating and maintenance personnel and are repeated here for emphasis.

WARNING
Do not attempt to lift the cart by the handle.

On page 4.

WARNING
Ethylene glycol is toxic. Do not take internally. Avoid contact with eyes, skin, and clothing. Avoid breathing vapor. Wash thoroughly after handling.

On page 5.

WARNING
Never attempt to connect or disconnect RF equipment from the transmission line while RF power is being applied. Leaking RF energy is a potential health hazard.

On pages 7, 12, 17, 18 and 23.

WARNING
To avoid personal injury, disconnect the power cord from the AC line before performing any maintenance, including fuse replacement.

On pages 11, 17, 18, 19, 23, 24 and 25.

WARNING
The Bird 4421 contains no user-serviceable parts. Do not remove its cover.

On page 11.

WARNING
Exposed AC line voltage (115 VAC or 230 VAC). Disconnect the power cord from the AC line before replacing the batteries. Failure to comply may result in severe electrical shock or death.

On pages 20 and 21.

WARNING
Use only Nickel Metal Hydride (NiMH) batteries that have a minimum capacity of 4500 milliampere hours (mAh). Do not install batteries that are not Nickel Metal Hydride. Do not install NiMH batteries that have less than 4500 mAh capacity. Failure to comply may result in damage to the batteries, damage to the instrument, and injury to personnel from battery chemicals.

On page 21

Caution Statements

The following equipment cautions appear in the text and are repeated here for emphasis.

CAUTION

Check the electrical code for proper AC hookup prior to operation of the unit. Make sure the neutral or return hookup is only used for that purpose.

On page 4.

CAUTION

Do not block air flow. The air intake vents on the side of the heat exchanger and the exhaust on top must not be obstructed.

On page 4.

CAUTION

Use only distilled water or ethylene glycol as coolant. Do not use tap water, automotive antifreeze, sealants, or leak stopping material. Use of these materials will damage the instrument and void all warranties.

On pages 5 and 12.

CAUTION

Operation without sufficient coolant will damage the unit.

On pages 5, 8 and 12.

CAUTION

Due to the complexity of the Bird Power Sensor, field repairs beyond general maintenance should not be attempted.
Removal or disturbance of the power sensor cover can result in cancellation of lifetime warranty.

On pages 14 and 18.

CAUTION

The Bird 4421 must be powered off when connecting or disconnecting the power sensor from the power meter.

On page 18.

CAUTION

Failure to install a properly rated fuse may result in damage to equipment or nuisance failure.

On page 19.

Safety Statements

USAGE

ANY USE OF THIS INSTRUMENT IN A MANNER NOT SPECIFIED BY THE MANUFACTURER MAY IMPAIR THE INSTRUMENT'S SAFETY PROTECTION.

USO

EL USO DE ESTE INSTRUMENTO DE MANERA NO ESPECIFICADA POR EL FABRICANTE, PUEDE ANULAR LA PROTECCIÓN DE SEGURIDAD DEL INSTRUMENTO.

BENUTZUNG

WIRD DAS GERÄT AUF ANDERE WEISE VERWENDET ALS VOM HERSTELLER BESCHRIEBEN, KANN DIE GERÄTESICHERHEIT BEEINTRÄCHTIGT WERDEN.

UTILISATION

TOUTE UTILISATION DE CET INSTRUMENT QUI N'EST PAS EXPLICITEMENT PRÉVUE PAR LE FABRICANT PEUT ENDOMMAGER LE DISPOSITIF DE PROTECTION DE L'INSTRUMENT.

IMPIEGO

QUALORA QUESTO STRUMENTO VENISSE UTILIZZATO IN MODO DIVERSO DA COME SPECIFICATO DAL PRODUTTORE LA PROIZIONE DI SICUREZZA POTREBBE VENIRNE COMPROMESSA.

SERVICE

SERVICING INSTRUCTIONS ARE FOR USE BY SERVICE - TRAINED PERSONNEL ONLY. TO AVOID DANGEROUS ELECTRIC SHOCK, DO NOT PERFORM ANY SERVICING UNLESS QUALIFIED TO DO SO.

SERVICIO

LAS INSTRUCCIONES DE SERVICIO SON PARA USO EXCLUSIVO DEL PERSONAL DE SERVICIO CAPACITADO. PARA EVITAR EL PELIGRO DE DESCARGAS ELÉCTRICAS, NO REALICE NINGÚN SERVICIO A MENOS QUE ESTÉ CAPACITADO PARA HACERLO.

WARTUNG

ANWEISUNGEN FÜR DIE WARTUNG DES GERÄTES GELTEN NUR FÜR GESCHULTES FACHPERSONAL.

ZUR VERMEIDUNG GEFÄHRLICHE, ELEKTRISCHE SCHOCKS, SIND WARTUNGSARBEITEN AUSSCHLIEßLICH VON QUALIFIZIERTEM SERVICEPERSONAL DURCHZUFÜHREN.

ENTRETIEN

L'EMPLOI DES INSTRUCTIONS D'ENTRETIEN DOIT ÊTRE RÉSERVÉ AU PERSONNEL FORMÉ AUX OPÉRATIONS D'ENTRETIEN. POUR PRÉVENIR UN CHOC ÉLECTRIQUE DANGEREUX, NE PAS EFFECTUER D'ENTRETIEN SI L'ON N'A PAS ÉTÉ QUALIFIÉ POUR CE FAIRE.

ASSISTENZA TECNICA

LE ISTRUZIONI RELATIVE ALL'ASSISTENZA SONO PREVISTE ESCLUSIVAMENTE PER IL PERSONALE OPPORTUNAMENTE ADDESTRATO. PER EVITARE PERICOLOSE SCOSSE ELETTRICHE NON EFFETTUARE ALCUNA RIPARAZIONE A MENO CHE QUALIFICATI A FARLA.

UNITS ARE EQUIPPED WITH RECHARGEABLE BATTERIES.

THESE ARE TO BE REPLACED BY AUTHORIZED SERVICE PERSONNEL ONLY!!!

LAS UNIDADES VIENEN EQUIPADAS CON BATERIAS RECARGABLES.

¡¡¡Y SOLAMENTE EL PERSONAL DE SERVICIO AUTORIZADO PUEDE REEMPLAZARLAS!!!

GERÄTE SIND MIT WIEDER AUFLADBAREN BATTERIEN BESTÜCKT.

BATTERIEN SIND NUR VON QUALIFIZIERTEM SERVICE PERSONAL AUSZUWECHSELN!!!

CES DISPOSITIFS SONT ÉQUIPÉS DE BATTERIES RECHARGEABLES.

SEUL LE PERSONNEL D'ENTRETIEN AUTORISÉ EST HABILITÉ À LES REMPLACER !

LE UNITÀ SONO DOTATE DI BATTERIE RICARICABILI,

CHE DEVONO DA COME SPECIFICATO DAL PRODUTTORE LA PROTEZIONE DI SICUREZZA POTREBBE VENIRNE COMPROMESSA.

USE CORRECT VOLTAGE SETTING AND FUSE - SEE MANUAL.

UTILISER UNE TENSION ET UN FUSIBLE CORRECTS - CONSULTER LE MODE D'EMPLOI.

USE LA INSTALACION Y FUSIBLE DE VOLTAJE CORRECTO - VEA EL MANUAL.

AUSSCHLIESSLICH VORSCHRIFTSMÄSSIGE WECHSELSPANNUNGS-EINSTELLUNG UND SICHERUNG BENUTZEN - SIEHE DAZU HANDBUCH.

UTILIZZARE TENSIONE E FUSIBLE ADATTI - FARE RIFERIMENTO AL MANUALE.

BE SURE THE 115/230V AC VOLTAGE SELECTOR IS SET TO THE PROPER LINE VOLTAGE, AND THE CORRECT AC LINE FUSE IS INSTALLED BEFORE AC POWER IS APPLIED.

S'ASSURER QUE LE SÉLECTEUR DE TENSION 115/230V C.A. EST BIEN RÉGLÉ POUR LA TENSION DU RÉSEAU ET QUE LE FUSIBLE DE LIGNE C.A. CORRECT EST EN PLACE AVANT DE METTRE SOUS TENSION C.A.

CERCIORSE QUE EL SELECTOR DE VOLTAJE DE 115/230V CA ESTE COLOCADO A LA LINEA DE VOLTAJE APROPIADA Y QUE EL FUSIBLE ESTE INSTALADO A LA LINEA CA ANTES DE APLICAR LA CORRIENTE ALTERNA.

VOR EINSCHALTEN DER WECHSELSTROMZUFUHR SICHERSTELLEN, DASS DER 115/230V WECHSELSPANNUNGS-SELEKTOR AUF DIE VORSCHRIFTSMÄSSIGE LEITUNGSSPANNUNG EINGESTELLT UND DIE RICHTIGE WECHSELSTROM-HAUPTSICHERUNG EINGESETZT IST.

PRIMA DI EROGARE CORRENTE, ASSICURARSI CHE IL SELETTORE DI VOLTAGGIO 115/230 V.C.A. SIA REGOLATO CORRETTAMENTE E CHE IL FUSIBLE ADATTO ALLA LINEA DI ALIMENTAZIONE C.A. SIA INSTALLATO.

About This Manual

This manual covers the operating & maintenance instructions for models with part numbers beginning with:

SCC8

Changes to this Manual

We have made every effort to ensure this manual is accurate. If you discover any errors, or if you have suggestions for improving this manual, please send your comments to our Solon, Ohio factory. This manual may be periodically updated. When inquiring about updates to this manual refer to the part number and revision on the title page.

Terminology

There are some unique terms used throughout this literature. They are defined here clarify any misunderstanding.

Cal Cart — The entire unit.

Sensor — The power sensor

Meter — The power meter and display

Load — The entire load (water-cooled RF termination).

Resistor Assembly — The load component which connects directly to the RF line. It is inside the HEAT EXCHANGER, connected by two hoses.

Heat Exchanger — The parts of the Moduload left when the LOAD is removed. It contains the pump, fans, coolant reservoir, and controls.

Resistor — A subcomponent of the RESISTOR ASSEMBLY. This is the ceramic resistor which actually absorbs the RF power.

Chapter Layout

Introduction — Describes the features of the Cal Cart, lists equipment supplied and optional equipment, and provides power-up instructions.

Setup — Describes the power supply and connection instructions.

Operating Instructions — Describes the base level operation instructions.

4421 Instructions — All instructions necessary to operate the 4421 Power Meter in conjunction with the Bird Semiconductor Cal Cart.

Maintenance — Lists routine maintenance tasks as well as troubleshooting for common problems. Specifications and parts information are also included.

TABLE OF CONTENTS

Safety Precautions	i
Safety Symbols	ii
Warning Statements	iii
Caution Statements	iv
Safety Statements	v
About This Manual	viii
Changes to this Manual	viii
Terminology	viii
Chapter Layout	viii
Chapter 1 Introduction	1
Items Supplied	1
RF Power Meter	1
Power Sensor	1
Load	2
Features	2
Indicators	2
Chapter 2 Setup	4
Unpacking and Inspection	4
Setup	4
Adding Coolant	5
Connecting RF Power	7
Chapter 3 Operating Instructions	8
Normal Operation	8
Shutdown	8
Chapter 4 4421 Instructions	9
Audible Warning	10
Chapter 5 Maintenance	11
Routine Maintenance	11
Inspection	11
DC Resistance	12
Changing the Coolant	13
Flushing the Coolant	13
Power Meter and Sensor Troubleshooting	14
Functional Test	14

Push Button Test	15
Load Troubleshooting	16
Repair	17
Removing the Front Panel	17
Replacing the Cord Reel	18
Replacing the Power Sensor	18
Replacing Fuses	19
Replacing Power Meter Batteries	20
Replace Batteries (Older models)	20
Replace Batteries (Newer models)	21
Load Servicing	23
Replacing Resistor Assembly	23
Removing the Pump	24
Resistor Assembly	25
Removing the Resistor	25
Inspecting the Resistor	26
Replacing a Fractured Resistor	26
Replacing the Resistor	27
Replacing the Conductor	27
Storage and Shipment	28
Storing the Load Resistor	28
Shipping the Load Resistor	28
Customer Service	29
Max. Power	30
Bird High Power Cal Cart	30
Bird 4421 RF Power Meter	30
Bird 4028B Series RF Power Sensors	31
Bird 8640S Series Moduloads	32
Replacement Parts	32
Cal Cart	32
Resistor Assembly	33
Heat Exchanger	33
Limited Warranty	36

This instruction book is intended for use by operators of the Bird High Power Cal Cart (HPCC). This chapter contains introductory information including component descriptions and items supplied.

The HPCC is designed for immediate, effortless use. It has three primary components. The Bird 4421 RF Power Meter displays RF power measurements. Bird 4028 Series Power Sensors are highly accurate sensors that measure RF power without requiring calibration or external couplers or attenuators. Bird Moduloads are low reflection 50 Ω terminations that can dissipate 25 kW. These components are installed on a cart for easy transportation. The cart is suitable for use in a cleanroom environment, and is equipped with four swivel casters for maximum maneuverability. The only setup required is adding coolant and connecting AC and RF power.

Items Supplied

Stainless Steel Cart with the following items installed:

- Bird 4421 RF Power Meter
- Bird 4028 Series Sensor
- Bird 8640 or 8640B Series Moduload
- Cabling
- Instruction Manual

RF Power Meter

The Bird 4421 RF Power Meter measures forward and reflected RF power when used with a Bird power sensor. Measurement units can be either Watts or dBm. Because of the quality of the attached load, reflected power will be negligible and can usually be ignored.

Note: *The 4421 is equipped with rechargeable batteries. These are shipped uncharged. Connect the unit to AC power the first time you use it to charge the batteries.*

Power Sensor

Bird 4028 Series Power Sensors are designed for use in semiconductor processing and calibration applications. 4028 Sensors are accurate to $\pm 2\%$ (2σ) at specified calibration frequencies and power levels. Sensors are controlled by the Power Meter.

Load

Bird Moduloads are self-cooling, nonradiating, low reflection terminations for high power RF lines. They dissipate up to 25 kW with a VSWR of less than 1.1:1 from 1 kHz to 900 MHz.

Features

- Useable with CW, AM, FM, SSB, and TV modulation, and certain pulse types.

Note: Contact Bird Electronic Corporation for information on using Moduloads with pulsed signals.

- Self-contained water-based cooling system

Indicators

- Coolant Level Gauge

Figure 1 Cal Cart Outline

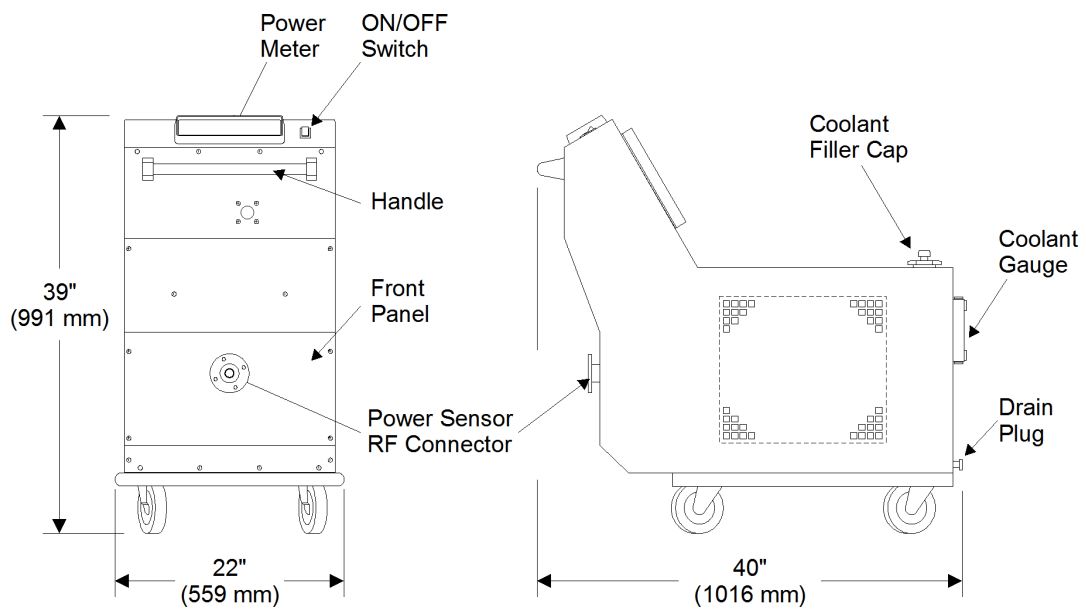
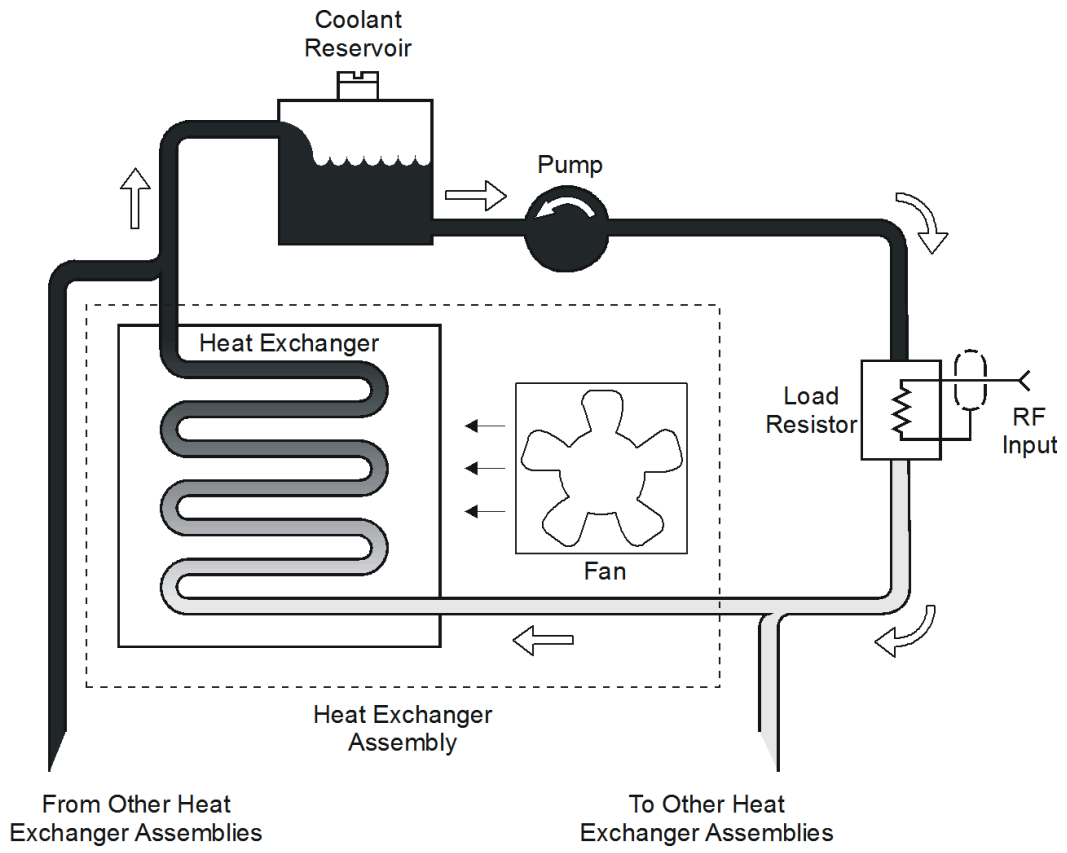

Figure 2 Load Cooling System Block Diagram



This chapter provides information for on-site requirements, unpacking, inspection, and preparing the Bird High Power Cal Cart for use.

Unpacking and Inspection

1. Carefully inspect shipping container for signs of damage.
 - If the shipping container is damaged, do not unpack the unit. Immediately notify the shipping carrier and Bird Technologies.
 - If the shipping container is not damaged, unpack the unit. Save shipping materials for repackaging.
2. Inspect unit for visual signs of damage.

Note: *If there is damage, immediately notify the shipping carrier and Bird Technologies.*

Setup

Setup consists of three basic steps: moving the unit into position, adding coolant, and connecting AC power and the RF line. These steps are explained in more detail below.

WARNING

Do not attempt to lift the cart by the handle.

CAUTION

Check the electrical code for proper AC hookup prior to operation of the unit. Make sure the neutral or return hookup is only used for that purpose.

CAUTION

Do not block air flow. The air intake vents on the side of the heat exchanger and the exhaust on top must not be obstructed.

- Use the HPCC in a dry, dust-free and vibration-free environment.
 - Note:** *Do not use outdoors or in areas of condensing humidity.*
- Allow a minimum of one foot clearance along the sides and three feet over the top to allow unobstructed air intake and exhaust.
- Surrounding air must be free of contaminants or particles that could be drawn into the air intakes.
- The AC power supply required is 115/230 V @ 50/60 Hz, 1 ϕ .

Note: *The unit is equipped with an unterminated, retractable power cord. Connect a power plug to this cord, appropriate to local power source.*

Coolant

WARNING

Ethylene glycol is toxic. Do not take internally.
Avoid contact with eyes, skin, and clothing. Avoid breathing vapor. Wash thoroughly after handling.

CAUTION

Use only distilled water or a distilled water/ethylene glycol mixture (with a maximum of 35% ethylene glycol) as coolant. Do not use tap water, automotive antifreeze, sealants, or leak stopping material. Use of these materials will damage the instrument and void all warranties.

Distilled water is the primary coolant for the unit. Ethylene glycol can be added to prevent bacterial growth and freezing; 10% to 35% ethylene glycol is recommended. Using at least 10% will prevent bacterial growth and at least 35% will prevent freezing to -20°C .

Note: *When using both ethylene glycol and distilled water, add the water first, then the ethylene glycol, to ensure proper mixing.*

[Figure 3 on page 6](#) shows the coolant's freezing point for a given percentage of ethylene glycol in the mix. The following example shows the weights to make a 65% distilled water to 35% ethylene glycol mixture in 5 and 55 gallon quantities.

	5 Gal. (18.9 L)	55 Gal. (208.2 L)
Distilled Water	28.0 lb (12.7 kg)	310 lb (140.6 kg)
Ethylene Glycol	15.2 lb (6.9 kg)	167 lb (75.7 kg)

Adding Coolant

CAUTION

Operation without sufficient coolant will damage the unit.

1. Make sure that the drain plug is in place.
2. Remove the filler cap on the top and at the rear of the unit.
3. Add about 3 quarts (2.9 L) of coolant.
4. Turn the unit on for a few seconds to draw coolant into the system.
5. Repeat steps 3 and 4 twice more, until the coolant remains steady at or just below the high mark on the level gauge.
6. Replace the filler cap.
7. Turn the unit on
8. Run the unit for five minutes to remove any air trapped in the system.

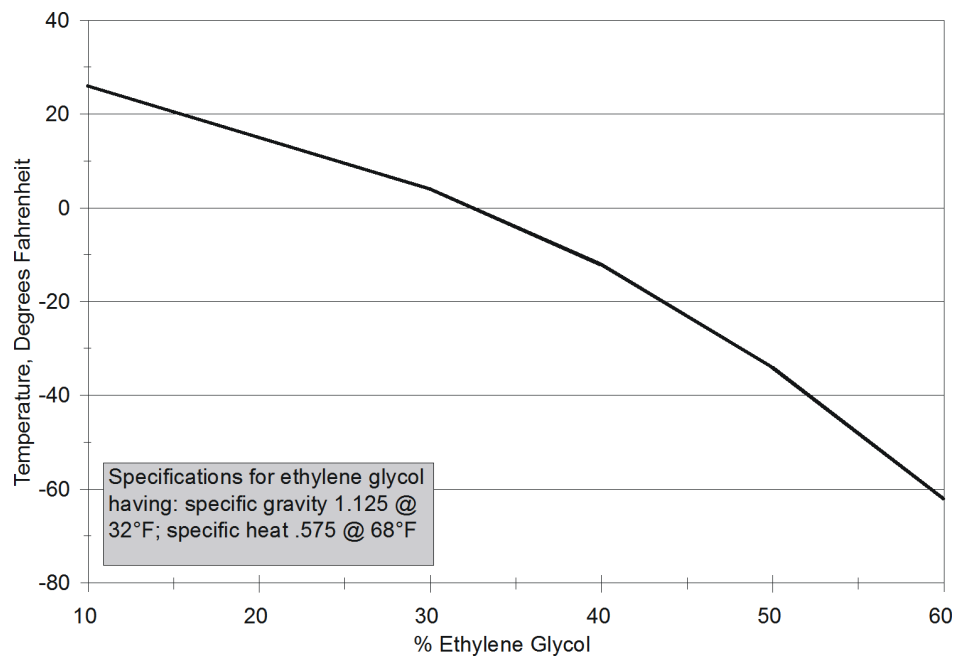
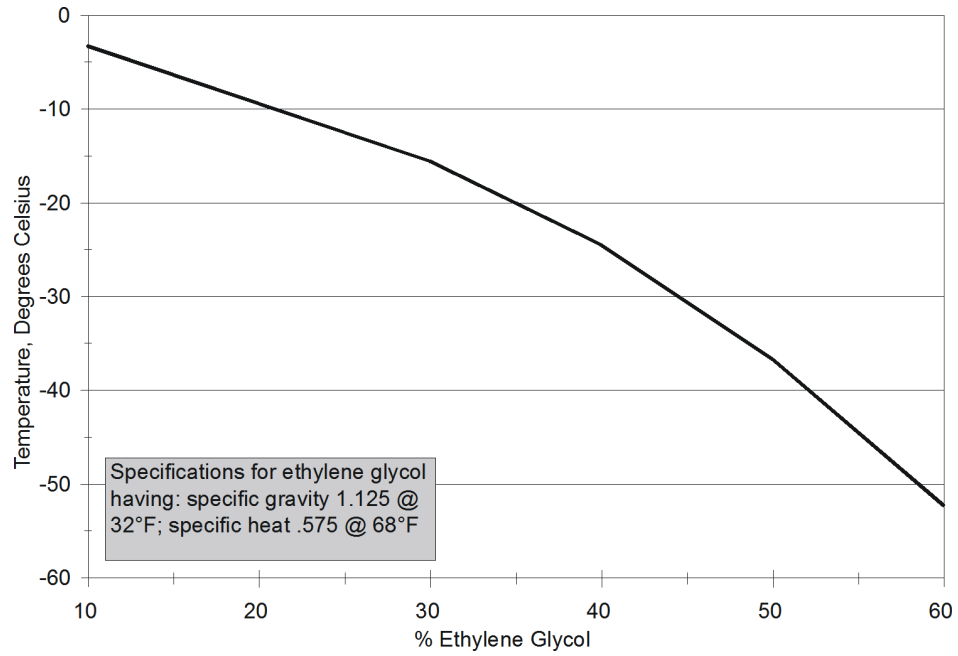
Figure 3 Freezing Point of Ethylene Glycol / Distilled Water Mixture

Connecting RF Power

CAUTION

Never attempt to connect or disconnect RF equipment from the transmission line while RF power is being applied.
Leaking RF energy is a potential health hazard.

After installing the Bird High Power Cal Cart, the RF transmission line can be attached using standard coaxial line coupling kits.

To couple the swivel flange with a flanged RF transmission line refer to [Figure 4](#) while following the instructions below:

Figure 4 Swivel Flanged Coupling

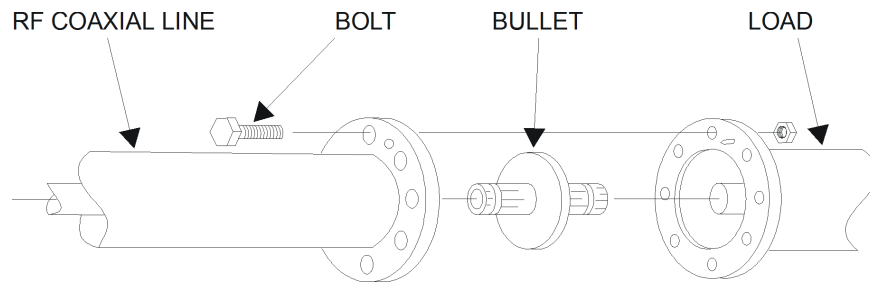

1. Insert the center bullet and push it in until it is fully seated.
2. Connect the coaxial input in a straight line and push carefully on the center conductor to close.

Note: *The swivel flange on the load makes connection independent of the orientation of the fixed flange on the coaxial input outer conductor.*

3. Insert the bolt sets and tighten evenly all around to transmission line manufacturer's recommended torque. Use all of the bolts.

WARNING

Never attempt to connect or disconnect RF equipment from the transmission line while RF power is being applied.
Leaking RF energy is a potential health hazard.

CAUTION

Operation without sufficient coolant will damage the unit.

Normal Operation

After setting up the Bird High Power Cal Cart:

1. Check that the coolant level is above the minimum mark on the rear coolant gauge.
2. Connect the unit to the AC line.
3. Check that the fans are running properly.
4. Turn on the Bird 4421 power meter.
5. Wait about 10 seconds for proper coolant flow.
6. Apply RF power.
7. Make measurements.

Note: See "[4421 Instructions](#)" on page 9 for specific instructions on controlling the meter.

Shutdown

1. Turn off RF power at the source.
2. Turn off the 4421 power the meter off.
3. Wait approximately 5 minutes for the load to cool to room temperature to prevent heat stress.
4. Disconnect the AC line.

Push Button Functions

Figure 5 Push Buttons

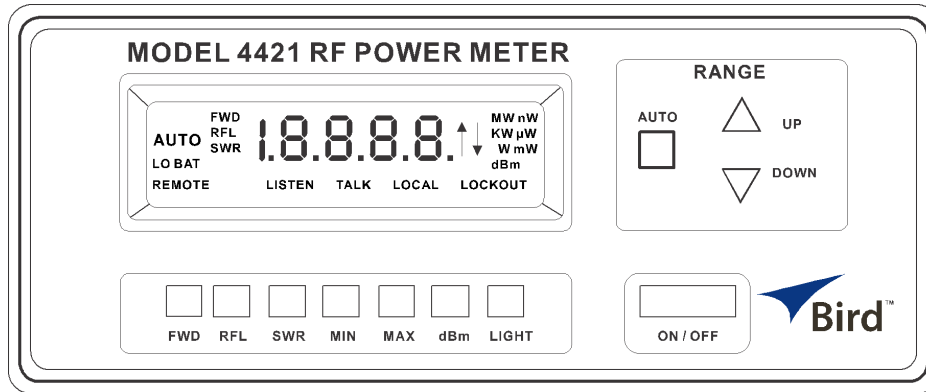

Push Button	Description
FWD, RFL	Press to measure forward (reflected) RF power. FWD (RFL) indicator and current unit of measure turn on.
SWR	Press to measure standing wave ratio. SWR indicator turns on. Value displayed will be between 1.0 and 199.9
MIN, MAX	Used after pressing FWD, RFL, SWR, or dBm. Displays the minimum (maximum) measured value of the previous function as long as MIN (MAX) is held down.
dBm	Used after pressing FWD or RFL. dBm indicator turns on. Power is displayed in dBm units. Used after pressing SWR. Return loss is displayed.
LIGHT	Press to turn on or turn off the display's backlight. If left on, the light automatically shuts off after 30 minutes.
AUTO	Press to automatically set the scale. AUTO turns on.
UP, DOWN	Press to select the next higher (lower) scale. If the scale is too high for the power sensor, an error will be displayed. Used while AUTO indicator is on. Stops automatic scaling. AUTO indicator turns off.
ON/OFF	Press to turn the power meter on or off.

Error Codes

The Bird 4421 displays error codes when the RF power is either below the selected range (underrange) or above the selected range (overrange). [Table 1](#) displays the error codes and [Table 2](#) lists the function limits.

Table 1 Error Codes

Symbol	Explanation
□□	Value greater than overrange limit of function
□□	Value less than underrange limit of function

Table 2 Function Limits

Function	Limit	Error
FWD, RFL	Power > 199.9% of full scale or 120% of top range	Ovrange
FWD dBm, RFL dBm	Power > 120% of full scale Power < 3% of low range	Ovrange Underrange
SWR	FWD < 20% of low range FWD – RFL = 0	Underrange Ovrange
Return Loss	FWD < 20% of low range RFL < 20% of low range Return Loss > 40 dB	Underrange Underrange Underrange

Audible Warning

If the RF power level exceeds 120% of the sensor's power range, the meter will sound a warning buzzer.

This chapter describes routine maintenance, along with troubleshooting instructions for the power meter and power sensor. Disassembly instructions for the Bird High Power Cal Cart are also provided. For service beyond this level, return the unit to a qualified service center.

WARNING

To avoid personal injury, disconnect the power cord from the AC line before performing any maintenance, including fuse replacement.

WARNING

Never attempt to connect or disconnect RF equipment from the transmission line while RF power is being applied.
Leaking RF energy is a potential health hazard.

WARNING

The Bird 4421 contains no user-serviceable parts.
Do not remove its cover.

This manual cannot list all malfunctions that may occur, or corrective actions. If a malfunction is not listed or is not corrected by the listed corrective actions, contact a qualified service center.

Routine Maintenance

Inspection

The HPCC requires only simple, routine maintenance.

- Wipe off dust and dirt regularly.
- Check the connectors and cables for damage.
- Clean the connector contacts with alcohol or dry cleaning solvent.
- If dust has collected on the radiator coils, remove the screws around the edge of the top panel, remove the panel, and vacuum the coils.
- The coolant level should be checked once a week, more often if the Cal Cart is used continuously or in high ambient temperatures.

Note: *The coolant level should be above the minimum mark on the gauge even when the unit is on. To add coolant, See ["Changing the Coolant" on page 13.](#)*

DC Resistance

Measuring the DC resistance between the inner and outer conductors of the RF connector shows changes in the load over time, a good check of the resistor's condition. Under normal operating conditions, the resistor should provide at least 5,000 hours of operation before requiring any additional service. DC resistance tracking must start before the load is put into service, and should be measured annually.

Perform the following steps and record the value for future comparison. Make sure that you have an ohmmeter with an accuracy of $\pm 1\%$ at 50 ohms and that the load temperature is between 20 and 25 °C (68 to 77 °F) before starting.

Figure 6 Measuring Resistance

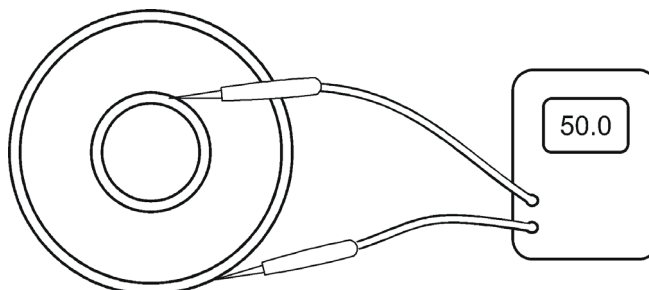

WARNING

Never attempt to connect or disconnect RF equipment from the transmission line while RF power is being applied. Leaking RF energy is a potential health hazard.

1. Turn off the RF power.
2. Disconnect the RF cables from the RF connectors on the load.
3. Check the load's center and outer conductors for visible damage or excessive wear.
4. Connect the multimeter test leads to the center and outer conductors. Refer to [Figure 6](#).
5. Compare the measured value with the previous measurement and with the baseline resistance, measured when the load was put into service.

Note: *If the new value differs from either of these by more than 2 ohms this could indicate a failing resistor.*

WARNING

Ethylene glycol is toxic. Do not take internally. Avoid contact with eyes, skin, and clothing. Avoid breathing vapor. Wash thoroughly after handling.

CAUTION

Use only distilled water or the supplied mixture of distilled water and ethylene glycol (with a maximum of 35% ethylene glycol) as coolant. Do not use tap water, automotive antifreeze, sealants, or leak stopping material. Use of these materials will damage the instrument and void all warranties.

CAUTION

Operation without sufficient coolant can damage the unit.

Changing the Coolant

Note: *To just add coolant, go to step 5. To just drain the coolant, follow steps 1 – 4.*

1. Get a clean container, with a capacity of 3 gal. (11 L), to hold the old coolant.
2. Remove the filler cap on the top and at the rear of the unit.

Note: *This will allow the coolant to drain faster.*

3. Unscrew and remove the drain plug at the bottom rear.
4. Drain the coolant into the container.

Note: *If the coolant has no contaminants it may be reused.*

5. Replace the drain plug and screw it tightly into place.
6. Add about 3 quarts (2.9 L) of coolant.
7. Turn the unit on for a few seconds to draw coolant into the system.
8. Repeat steps 6 and 7 twice more, until the coolant remains steady at or just below the high mark on the level gauge.
9. Replace the filler cap.
10. Turn the unit on and run it for five minutes to remove any air trapped in the system.

Flushing the Coolant

Note: *If the coolant is contaminated, for example by pipe sealant or a broken resistor, the system should be thoroughly flushed.*

1. Fill the unit with clean, potable water.
2. Run the unit for five minutes with no RF power applied.
3. Drain the coolant and discard it.
4. Repeat steps 1 – 3 until the drained liquid is clear.
5. Refill the system with proper coolant (distilled water or a distilled water/ethylene glycol mixture) as described above.

Power Meter and Sensor Troubleshooting

Since the power meter and power sensor can only work together, the first step is to determine which is malfunctioning. Connect the power sensor to the meter and perform the functional test on [page 14](#). If the power meter is malfunctioning, refer to the troubleshooting table below. If the power sensor is malfunctioning, return it for service.

CAUTION

Due to the complexity of the Bird Power Sensor, field repairs beyond general maintenance should not be attempted. Removal or disturbance of the power sensor cover can result in cancellation of lifetime warranty.

PROBLEM	POSSIBLE CAUSE	CORRECTION
Power meter has no power	Have the batteries been charged?	Recharge the batteries.
	Is the power meter's AC power cord connected to the terminal strip?	Connect the power cord.
	Is the Cal Cart's AC power cord connected to the AC line?	Connect AC power.
	Is the ON/OFF rocker switch on the rear panel set to OFF?	Set the switch to ON.
	Unplug the Cal Cart. Has the power meter fuse blown?	Replace fuse (See " Replacing Fuses " on page 19).
Dash moves across the display	Is the AC power cord defective?	Replace AC power cord.
	Is the sensor cable connected to both the power meter and power sensor?	Connect sensor cable.
	Is the sensor cable defective?	Replace sensor cable.
Display blank or not updating	Have the batteries been charged?	NO: Recharge battery YES: Return meter for service.
Power meter turns off while on battery power	Is "LO BAT" displayed?	YES: Recharge battery NO: Return meter for service.
Push buttons do not respond	Test the push buttons (See " Push Button Test " on page 15). Are they defective?	Return meter for service.
Every segment on the display is lit		Return meter for service.

Functional Test

1. Disconnect the AC power cable and turn the power meter off.

Note: *The On/Off switch on the rear panel of the meter should be On.*
2. Connect the AC power cable.
3. Press the On/Off button on the *front* panel of the power meter while holding down the FWD and SWR push buttons, .
4. Immediately release all three.

5. Ensure that both of following happen:
 - The power meter’s model number and revision date should scroll across the display.

Note: If a dash “-” is displayed instead, then the meter is malfunctioning.
 - The power sensor’s model number and revision date should scroll across the display.

Note: If a dash “-” is displayed after the power meter data, then the power sensor is malfunctioning.

Figure 7 Test Display, No Malfunction

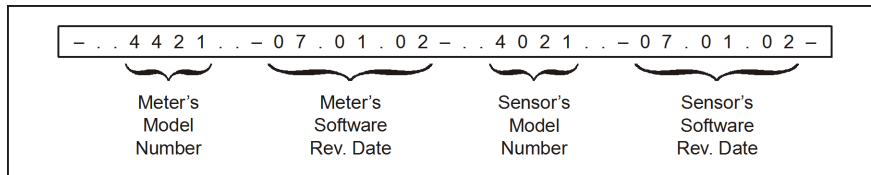

Push Button Test

Note: This test checks that the push buttons and display are functioning properly. If a push button is malfunctioning, return the power meter.

1. Disconnect the power sensor.
2. Turn the power meter On.

Note: After the power up display disappears, three dashes “- - -” should scroll across the display.
3. “AUTO” and “FWD” should be displayed, and a reading of “.000 W”.
4. Press RFL. “FWD” should change to “RFL” on the display.

Note: The reading should remain the same.
5. Press SWR.

Note: “RFL” should change to “SWR”. “.000 W” should change to “□ □” (underrange error).
6. Hold down MIN.

Note: “□ □” should change to “□ □” (overrange error).
7. Release MIN.

Note: “□ □” should change to “□ □”.
8. Hold down MAX.

Note: “□ □” should change to “.000”.
9. Release MAX.

Note: “.000” should change to “□ □”.
10. Press dBm.

Note: “SWR” should change to “dBm”.
11. Press dBm.

Note: “dBm” should change to “SWR”.
12. Press FWD.

Note: “SWR” should change to “FWD”. “□ □” should change to “.000 W”.
13. Press LIGHT.

Note: The back-light should turn on.
14. Press LIGHT.

Note: The back-light should turn off.

15. Press S (up).

Note: The power meter should change ranges each time it is pressed until it reaches “.000 KW”. Press † (down).

Note: The power meter should change ranges each time it is pressed until it reaches “.000 W”.

16. Turn the power meter OFF.

Load Troubleshooting

PROBLEM	POSSIBLE CAUSE	CORRECTION
Blower not operating	Is the load's AC power cord connected to the terminal strip?	Connect the power cord.
	Is the Cal Cart's AC power cord connected to the AC line?	Connect AC power.
	Unit turned off.	Set the line switch to ON.
	Fuse burnout.	Replace fuse (See " Replacing Fuses " on page 19).
Coolant leaking	Loose connections.	Tighten drain plug and all connections.
	Worn or cracked tubing.	Replace defective tubing.
Excessive reflected power	Resistor's DC resistance has changed.	Check DC resistance. See " DC Resistance " on page 12).

Repair

WARNING

To avoid personal injury, disconnect the power cord from the AC line before performing any maintenance, including fuse replacement.

WARNING

Never attempt to connect or disconnect RF equipment from the transmission line while RF power is being applied.
Leaking RF energy is a potential health hazard.

Removing the Front Panel

Note: To access the power sensor or the AC connections, it will be necessary to remove the cart's front panel.

1. Remove the screws on the front panel.
2. Pull on the handle set into the base of the front panel to remove it.
3. When making AC connections, refer to the wiring diagram below.

Figure 8 Cal Cart Outline

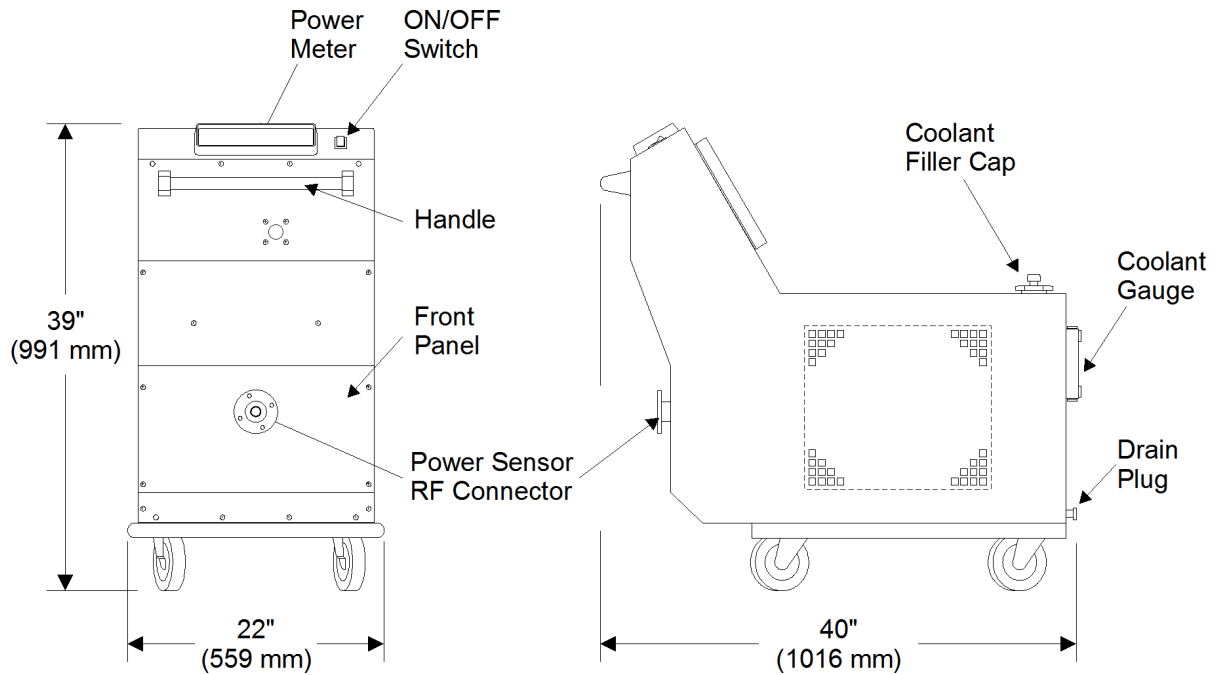

Replacing the Cord Reel

1. Disconnect the cord reel from the terminal strip.
2. Unscrew the AC connector.
3. Unscrew and remove the cord reel.
4. Screw the replacement cord reel into place.
5. Replace the ring terminal and quick disconnects on the cord reel.
6. Thread the AC connector through the grommet, and connect the wires on the other end to the terminal strip (See [Figure 9](#)).

Figure 9 Cal Cart Wiring Schematic

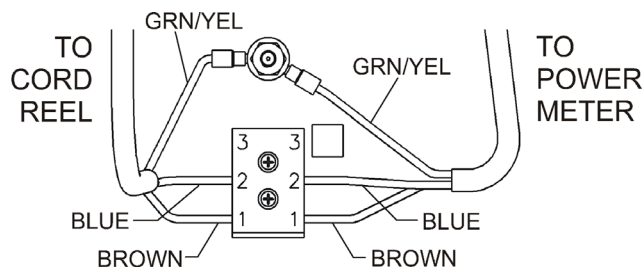

Replacing the Power Sensor

WARNING

To avoid personal injury, disconnect the power cord from the AC line before performing any maintenance, including fuse replacement.

WARNING

Never attempt to connect or disconnect RF equipment from the transmission line while RF power is being applied.
Leaking RF energy is a potential health hazard.

CAUTION

The Bird 4421 must be powered off when connecting or disconnecting the power sensor from the power meter.

CAUTION

Due to the complexity of the Bird Power Sensor, field repairs beyond general maintenance should not be attempted.
Removal or disturbance of the power sensor cover can result in cancellation of lifetime warranty.

1. Disconnect the RF line from the HPCC.
2. Remove the unit's front panel (see "[Removing the Front Panel](#)" on page 17).
3. Disconnect the sensor cable from the power sensor.
4. Disconnect the RF cable from the sensor output port.
5. Remove the screws on the sensor mounting bracket and remove the sensor from the mounting bracket.
6. Put the new sensor in the bracket and screw it into place.

Note: Make sure the arrow on the side of the sensor points towards the load, and that the end labeled "SOURCE" points towards the front of the Cal Cart.

7. Connect the RF cable to the sensor end labeled "LOAD".
8. Connect the sensor cable.
9. Replace the unit's front panel.

Replacing Fuses

WARNING

To avoid personal injury, disconnect the power cord from the AC line before performing any maintenance, including fuse replacement.

CAUTION

Failure to install the properly rated fuse may result in equipment damage or nuisance failures.

1. Gently pry the fuse drawer out of the AC module.

Note: The fuse holder does not detach from the AC module.

2. Install the replacement fuses then close and secure the fuse holder. Fuse 1 is a spare fuse and fuse 2 is the active fuse.

AC Line Voltage	Fuse Rating
115 Vac	T630 mA, 5x20 mm Time Lag Fuse
230 Vac	T315 mA, 5x20 mm Time Lag Fuse

Figure 10 AC Line Fuse

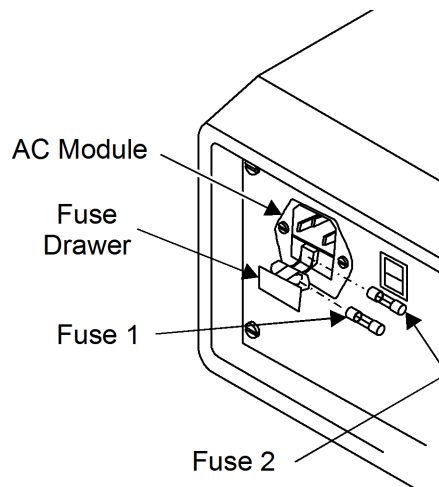

Replacing Power Meter Batteries

There are two battery configurations in the 4421 Power Meter. In the larger case models (before 2016), the batteries are horizontally arranged, in units with a smaller case the batteries are vertically arranged in a battery assembly.

Replace Batteries (Older models)

WARNING

Exposed AC line voltage (115 VAC or 230 VAC). Disconnect the power cord from the AC line before replacing the batteries. Failure to comply may result in severe electrical shock or death.

1. Disconnect the AC power cord from the AC mains supply.
2. Remove the four screws that secure the top cover.
3. Lift the top cover to access the attached ground wire then disconnect the ground wire and remove the cover.
4. Unfasten the battery retaining belts then remove the battery tubes ([Figure 11](#)).

Note: Be sure to note the polarity and orientation of the battery tubes before removing them.

5. Remove the batteries from each tube and insert replacement batteries.

Note: Be sure to note the polarity (positive and negative) arrangement of the batteries.

6. Install the battery tubes into the unit and secure with the retaining belts.

Note: Be sure to position the retaining belts as they were before removal and tighten them securely.

7. Connect the ground wire to the top cover.
8. Install the top cover.
9. Secure the top cover with the four screws removed earlier.

Figure 11 Batteries

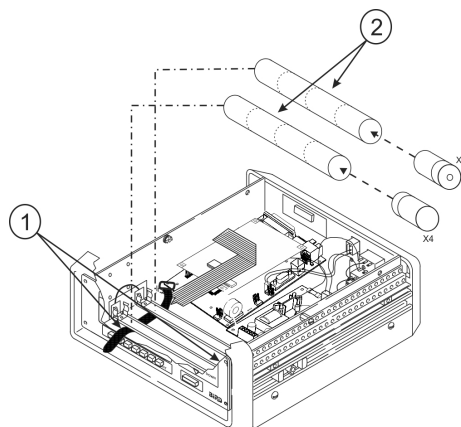

Item	Description
1	Battery retaining belt
2	Battery tube (batteries inside)

Replace Batteries (Newer models)

WARNING

Exposed AC line voltage (115 VAC or 230 VAC). Disconnect the power cord from the AC line before replacing the batteries. Failure to comply may result in severe electrical shock or death.

WARNING

Use only Nickel Metal Hydride (NiMH) batteries that have a minimum capacity of 4500 milliampere hours (mAh). Do not install batteries that are not Nickel Metal Hydride. Do not install NiMH batteries that have less than 4500 mAh capacity. Failure to comply may result in damage to the batteries, damage to the instrument, and injury to personnel from battery chemicals.

1. Disconnect the AC power cord from the ac mains supply.
2. Remove the four screws that secure the top cover.
3. Lift the top cover to access the attached ground wire then disconnect the ground wire and remove the cover.
4. Remove two retaining screws securing the battery assembly. See [Figure 12](#).
5. Disconnect battery assembly power supply connector.

Figure 12 Battery Assembly Removal

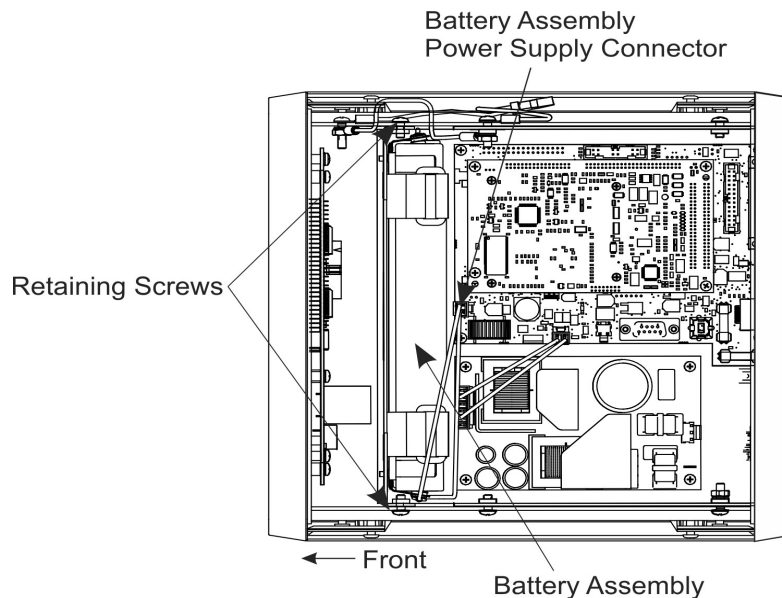

6. Lift the battery assembly out of the Power Meter.
7. Unfasten the battery retaining belts then remove the battery tubes ([Figure 13](#)). Be sure to note the polarity and orientation of the battery tubes before removing them.

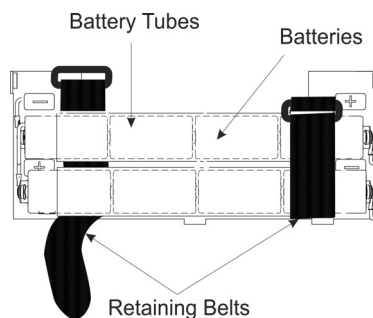
Figure 13 Battery Assembly

8. Remove the batteries from each tube and insert replacement batteries. Be sure to note the polarity (positive and negative) arrangement of the batteries.
9. Install the battery tubes into the battery assembly and secure with the retaining belts. Be sure to position the retaining belts as they were before removal and tighten them securely.
10. Install battery assembly in the Power Meter. Align tabs on battery assembly with slots in Power Meter.
11. Install two screws to secure battery assembly to Power Meter.
12. Connect the battery assembly power supply connector to the main board.
13. Connect the ground wire to the top cover.
14. Install the top cover and secure it with the four screws removed earlier.

Load Servicing

Replacing Resistor Assembly

WARNING

To avoid personal injury, disconnect the power cord from the AC line before performing any maintenance, including fuse replacement.

WARNING

Never attempt to connect or disconnect RF equipment from the transmission line while RF power is being applied.
Leaking RF energy is a potential health hazard.

1. Disconnect the RF line from the Cal Cart
2. Disconnect the Sensor from the Load.
3. Remove the Cal Cart front panel (see ["Removing the Front Panel" on page 17](#)).
4. Disconnect the load's AC line from the terminal strip.
5. Drain the coolant (See ["Changing the Coolant" on page 13](#)).
6. Remove the screws around the edge of the top panel
7. Raise the top panel only high enough to gain access to the fan supply plug.
8. Disconnect the fan-supply plug on top of the radiator block by pressing the latch in the center of the plug while pulling away from the mating connector.
9. Unscrew the hose clamps on both water connections to the resistor assembly.
10. Remove the nuts, on the inside of the front panel, holding the assembly to the front panel.
Note: *Remove the nuts only. Do not disturb the screws. The screws also secure the outer conductor assembly to the resistor. Hold this assembly to keep it from falling and being damaged.*
11. Unscrew the mounting clamp holding the resistor assembly to the rest of the unit.
12. Remove the top half of the clamp.
13. Carefully push the assembly forward a few inches to access the wires and water connection fittings.
14. Note the position and direction of the output elbow then unscrew it from the load.
15. The resistor assembly can now be removed.

Removing the Pump

WARNING

To avoid personal injury, disconnect the power cord from the AC line before performing any maintenance, including fuse replacement.

1. Drain the coolant (See ["Changing the Coolant" on page 13](#)).
2. Remove the load (See ["Replacing Resistor Assembly" on page 23](#)).
3. Disconnect the pump wire leads from the terminal block on the inside of the front panel.
4. Loosen the hose clamps on the input and output hoses to the pump, and remove the hoses.
5. Unscrew the hex nut on the drain tube at the base of the pump. Remove the drain tube.
6. Unscrew the bolts securing the base of the pump to the unit.
7. Remove the pump, carefully, from the unit.
8. Note the position and direction of the fittings, then twist them off counterclockwise.
9. To replace the pump, reverse the above steps.

Note: *When replacing the threaded fittings, carefully coat the external threads, ONLY, with a pipe sealing compound. Coating only the external threads reduces the chances of contaminating the coolant.*

Resistor Assembly

The load is designed to be quickly and easily repaired in the field. If a significant change in the DC resistance is noted or if the resistor should fail, inexpensive replacement resistors are available.

WARNING

To avoid personal injury, disconnect the power cord from the AC line before performing any maintenance, including fuse replacement.

Figure 14 Load Exploded View

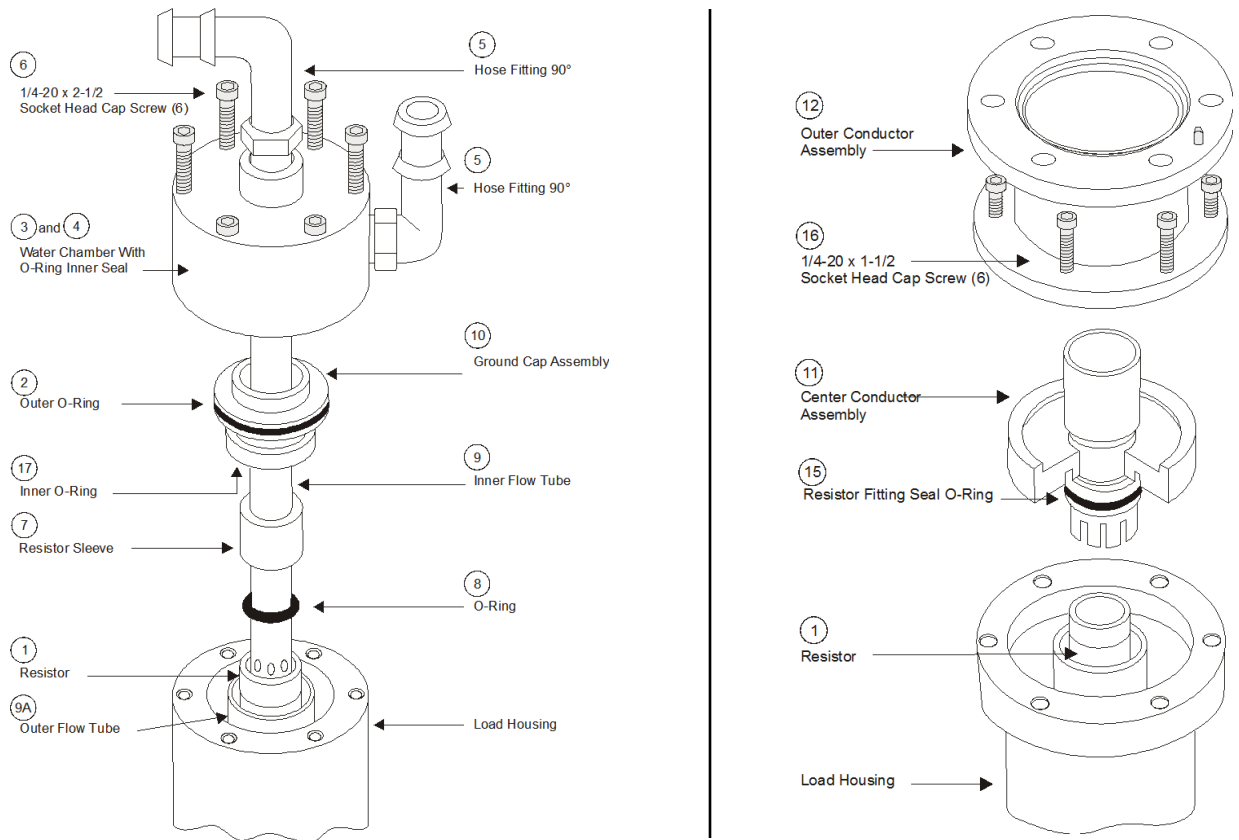

Removing the Resistor

Note: Numbers in brackets [] refer to the labeled parts in Figure 14.

1. Remove the resistor assembly. (see "[Replacing Resistor Assembly](#)" on page 23).
2. Turn the assembly on end with the hose fitting up.

Note: Use a $\frac{3}{16}$ hex socket wrench to tighten the cap screws [6] approximately $\frac{1}{2}$ inch-lbs.

3. Pull the water chamber assembly out.

Note: It may be necessary to rock the chamber gently while pulling.

4. Remove the following parts and set them aside for reassembly:
 - Inner flow tube [9]
 - Resistor sleeve [7]

- Cushioning O-ring [8]
5. Remove the ground cap assembly by gently prying it upward using the flat blade of a screw driver and working around the circumference of the part until it is free.
Note: *The ground cap assembly [10] should now be exposed on the resistor at the end of the load housing.*
 6. Pull the resistor [1] straight out using a gentle rocking motion.
Note: *Do this only if the resistor [1] is intact.*
Note: *The resistor sleeve [7] has a small escape hole at the side and an access counter bore leading to it. If the sleeve is removed, be sure this counterbore faces the O-Ring and the resistor [1] during reassembly. This is essential for internal water venting. The base of the inner flow tube has water outlet holes and a small shoulder. At reassembly, these must fit into mating recesses in the input fitting.*

Inspecting the Resistor

1. Carefully check the resistor [1] for fractures.
Note: *Even in the event of failure the resistor substrate will usually remain intact.*
2. Check the inside of the housing for damage to the internal parts.
3. Do one of the following:
 - If the resistor is broken, other internal parts are damaged, or if the parts do not fit together properly, proceed to ["Replacing a Fractured Resistor" on page 26](#).
 - If no damage has been found, proceed to ["Replacing the Resistor" on page 27](#).

Replacing a Fractured Resistor

1. Turn the assembly on end with the RF input connector up to allow any loose pieces of the resistor to fall out of the housing.
2. Use a $\frac{3}{16}$ hex socket wrench to remove the cap screws [16].
3. Remove the outer conductor assembly [12].
4. Pull out the center conductor assembly [11].
5. Remove, carefully, any remaining pieces of the resistor.
Note: *Normally the outer flow tube will remain with the housing. If it comes out, return it after inspection and cleaning.*
6. Check the inside of the housing for damage.
7. Remove the inner flow tube [9] and ground cap assembly [10].
8. Check inner flow tube and ground cap assembly for broken pieces.
9. Wash, thoroughly, the inside of the conductor assemblies, housing and water chamber under clear running water.
10. Replace the ground cap assembly and the inner flow tube.

Replacing the Resistor

1. Insert the new resistor [1] into the resistor fitting of the center conductor assembly [15] to test its tightness.
Note: *The resistor should be snug but should not have to be forced into the fitting. If the resistor is too loose:*
 - a. Press the fitting fingers together slightly
 - b. Insert the resistor again.
 - c. Continue closing the ends of the resistor fitting until a snug fit is obtained.
2. Bottom the resistor in the fitting.
3. Insert the resistor and center conductor assembly into the housing.
4. Replace the outer conductor assembly [12] and screw it into place.
5. Stand the load on its end with the RF connector down.
6. Replace the ground cap assembly onto the exposed end of the resistor.
Note: *Make sure that it seats on the load housing.*
7. Do one of the following:
 - If the inner flow tube [9] is separated from the water chamber assembly [3]:
 - a. Place it inside the resistor
 - b. Lower until it reaches the resistor fitting.
 - c. Twist, gently, the flow tube until it seats in the bottom of the resistor fitting.
 - If the inner flow tube [9] is not separated from the water chamber assembly [3], proceed to Step 4.
8. Check that the O-Ring [8] is on the inner flow tube next to the resistor and the resistor sleeve [7] is right behind it.
Note: *Make sure the counterbore faces the O-Ring and the resistor.*
9. Replace the water chamber [3], gently rocking and twisting the chamber to achieve a flat seat on the outer housing.
Note: *If the water chamber does not fit properly make sure that the inner flow tube is properly placed.*
10. Tighten the water chamber screws [6].
11. Check the DC resistance between the inner and outer conductors; it should be about 50 ohms.
Note: *Record this measurement as the new baseline reading.*
12. Install the resistor assembly on the heat exchanger.
13. Connect the hoses and fill with coolant.
14. Run the pump for five minutes and check for leaks before applying RF power.

Replacing the Conductor

1. Remove the cap screws [16] from the RF connector, using a $\frac{3}{16}$ Allen wrench.
2. Remove the outer conductor assembly [12].
Note: *If only the outer conductor needs replaced, install it now and screw it into place.*
3. Remove the center conductor assembly [11] by pulling it carefully out of the load housing.
Note: *Make sure the resistor [1] and inner flow tube [9] do not come out with the center conductor.*
4. Insert the new center conductor assembly into load housing.
Note: *Make sure the resistor fitting makes a snug fit with the resistor.*
5. Replace the outer conductor and screw it into place.

Storage and Shipment

Storing the Load Resistor

1. Cover Bird HPCC Loads before storing to keep out dust and dirt.
2. It is not necessary to install the shipping plug.
3. Store in a dry, dust-free environment where the ambient temperature will remain between -40 and $+45$ °C (-40 to $+113$ °F).

Shipping the Load Resistor

1. Remove the vent plug.
2. Install the shipping plug.
3. Wrap the vent plug with padding and tape it to the side of the load for protection.

Note: *With the shipping plug installed, it is not necessary to empty out the coolant.*

4. Wrap the connector in padding.
5. Pack and brace the load in a sturdy wooden crate for shipment.

Customer Service

Any maintenance or service procedure beyond the scope of those in this chapter should be referred to a qualified service center.

If the unit needs to be returned for any reason, request an Return Material Authorization (RMA) through the Bird Technologies website. All instruments returned must be shipped prepaid and to the attention of the RMA number.

Bird Service Center

30303 Aurora Road
Cleveland (Solon), Ohio 44139-2794
Fax: (440) 248-5426
E-mail: bsc@birdrf.com

For the location of the Sales Office nearest you, visit our Web site at:

<http://www.birdrf.com>

Specifications

Note: Certain sensors or connectors may be incompatible with some models. For a list of available components, contact Bird Applications Engineering.

Max. Power

The Cal Cart's maximum power is the MINIMUM of the max. power of the sensor and the max. power of the load, under normal conditions.

Bird High Power Cal Cart

Frequency Range	Sensor dependent
Power Range	Dependent on sensor, sensor connectors, and load
Connectors	1-5/8" Flanged
Dimensions	40"L x 22"W x 39"H (1005 x 550 x 991 mm)
Weight, Nominal	240 lbs. (109 kg)
Temperature	Load coolant dependent
Calibration Cycle	1 year

Bird 4421 RF Power Meter

VSWR Display	1.0 – 199.9 max
Return Loss Display	0 to 40 dB max
Display Accuracy	± 1 on least significant digit
AC Power	115/230 Vac @ 50/60 Hz
Batteries	8 Nickel Metal Hydride rechargeable 1.2 volt cells
Battery Life	Approximately 8 hours continuous usage
Battery Charger	Built-in battery charger. Drained batteries require approximately 28 hours to recharge.
Display	LCD, 4½ digit display. Indicates mode, measurement units, battery condition, remote status, and signal increase / decrease. Self contained backlight.
Fuse Rating 115 Vac 230 Vac	IEC (5 x 20 mm) Time Lag Type T T630 ma T315 ma
Dimensions, Nominal	15.5"L x 12.25"W x 4.25"H (393 x 311 x 108 mm)
Weight, Nominal	9.5 lbs. (4.3 kg)

Bird 4028B Series RF Power Sensors

Frequency Range 4028B10M	10 – 15 MHz
RF Power Range	1 kW – 25 kW
Accuracy, Fwd, Best Case ¹	± 2.0% (2σ)
Accuracy, Reflected	Calculated from FWD accuracy and FWD power $\text{RFL Accuracy} = \text{FWD Accuracy} + \frac{\text{FWD Power}}{10^{\text{Directivity}/10}}$
Accuracy, VSWR	Calculated from FWD and RFL power $\text{VSWR} = \left(1 + \sqrt{\frac{P_R}{P_F}} \right) / \left(1 - \sqrt{\frac{P_R}{P_F}} \right)$
Calibration Frequencies, Typical (MHz)² 4028B10M	10.0, 13.56, 15.0
Calibration Power, Typical	3.5 kW
VSWR, Max.	1.05:1
Insertion Loss, Max.	0.05 dB
Directivity, Min.	28 dB
Impedance, Nominal	50 ohms
VSWR Range	1.00 to 2.00 (40.0 to 9.5 dB Return Loss)
Max. Allowable Terminating VSWR	2.00:1
Calibration Technique	Calibration vs. frequency curve stored in nonvolatile memory in each sensor. Sensor output corrected at frequency of measurement within rated range.
Sampling Rate, Nominal	2 readings/second
Operating Power	Supplied by power meter via sensor cable
Dimensions, Nominal	6.75”L x 3.5”W x 4.75”H (175 x 89 x 121 mm)
Weight, Nominal	5 lb. 2 oz. (2.33 kg)

- 1 For rated accuracy, no more than 1% AM; Harmonics –50 dBc or less
 Derate accuracy by 2% (2σ) outside cal. power or cal. frequency
 Derate accuracy by 2% (2σ) below 15 °C and above 35 °C
- 2 Other calibration frequencies available upon request

Bird 8640S Series Moduloads

Frequency Range	1 kHz – 900 MHz
Power Rating	25 kW continuous duty
Mode	CW, AM, FM, SSB, TV and certain pulse types
Impedance, Nominal	50 ohms
VSWR, Max	1.10:1
Cooling Method	Water dielectric and forced air convection
Coolant ¹	Distilled water or distilled water/ethylene glycol mixture
Coolant Capacity	9 qts. (8.5 L) nominal
AC Power	115/230 Vac @ 50/60 Hz
Fuse Rating 115 Vac 230 Vac	15 A (3AB time delay) 8 A (5x20 mm time delay)
Operating Temperature ² Water only 35% Ethylene Glycol	5 to 45 °C (41 to 113 °F) ² 0 to 35 °C (32 to 95 °F) ²
Storage Temperature Water only 35% E.G.	+5 to +50 °C (41 to 122 °F) –20 to +50 °C (–4 to +122 °F)

1 Below 5°C, ONLY use 35% E.G. and 65% Dist. H₂O mixture

2 Above 30°C (86 °F) with water only, or 25°C (77 °F) with a 35% ethylene glycol mixture, derate power to 20 kW max.

Replacement Parts

Cal Cart

Description	Qty	Part Number
Power Meter Fuse, IEC (5 x 20 mm) Type T 115 Vac, T630 mA 230 Vac, T315 mA	1	5A2257-14 5A2257-11
Cord, AC Power, Power Meter 115 Vac 230 Vac Harmonized	1	5-1286 5A2416
Plug, 115 Vac	1	5A2626
Cable, Sensor	1	4421-038
Grommet	1	SA2617-20
Cordreel	1	4421A383-2
Handle	1	4421A385

Resistor Assembly

Exploded views are used to illustrate the parts below and indicate their relation to each other. Each part in the exploded view has an item number referencing this list.

Item No.	Description	Qty	Part Number
1	Resistor	1	8755-027
2	Outer O-Ring	1	8410-009
3	Water Chamber	1	8755-014
4	Water Chamber Inner O-Ring	1	5-099
5	Fitting, 90°	2	8640-089
6	Screw 1/4-20 x 2-1/2"	6	1121-2508-00
7	Resistor Sleeve	1	8755-026
8	Sleeve O-Ring	1	8110-059
9	Inner Flow Tube	1	8755-025
9A	Outer Flow Tube	1	8755-024
10	Resistor Ground Cap	1	8755-005
15	Center Conductor O-Ring	1	5-1127
16	Screw 1/4-20 x 1 1/2"	6	1121-1808-00
17	Inner O-Ring	1	5-567

Heat Exchanger

Description	Qty	Part Number
Cord, AC Power 115 Vac 230 Vac	1	5-1836 5-1837
Fuse 115 Vac, 15 A (3AB time delay) 230 Vac, 8 A (5x20 mm time delay)	2	5-1828-36 5A2257-25
Coolant Gauge Kit	1	5-1200
Ethylene Glycol	1 Gal.	5-1134-3

Figure 15 Resistor Assembly Exploded View

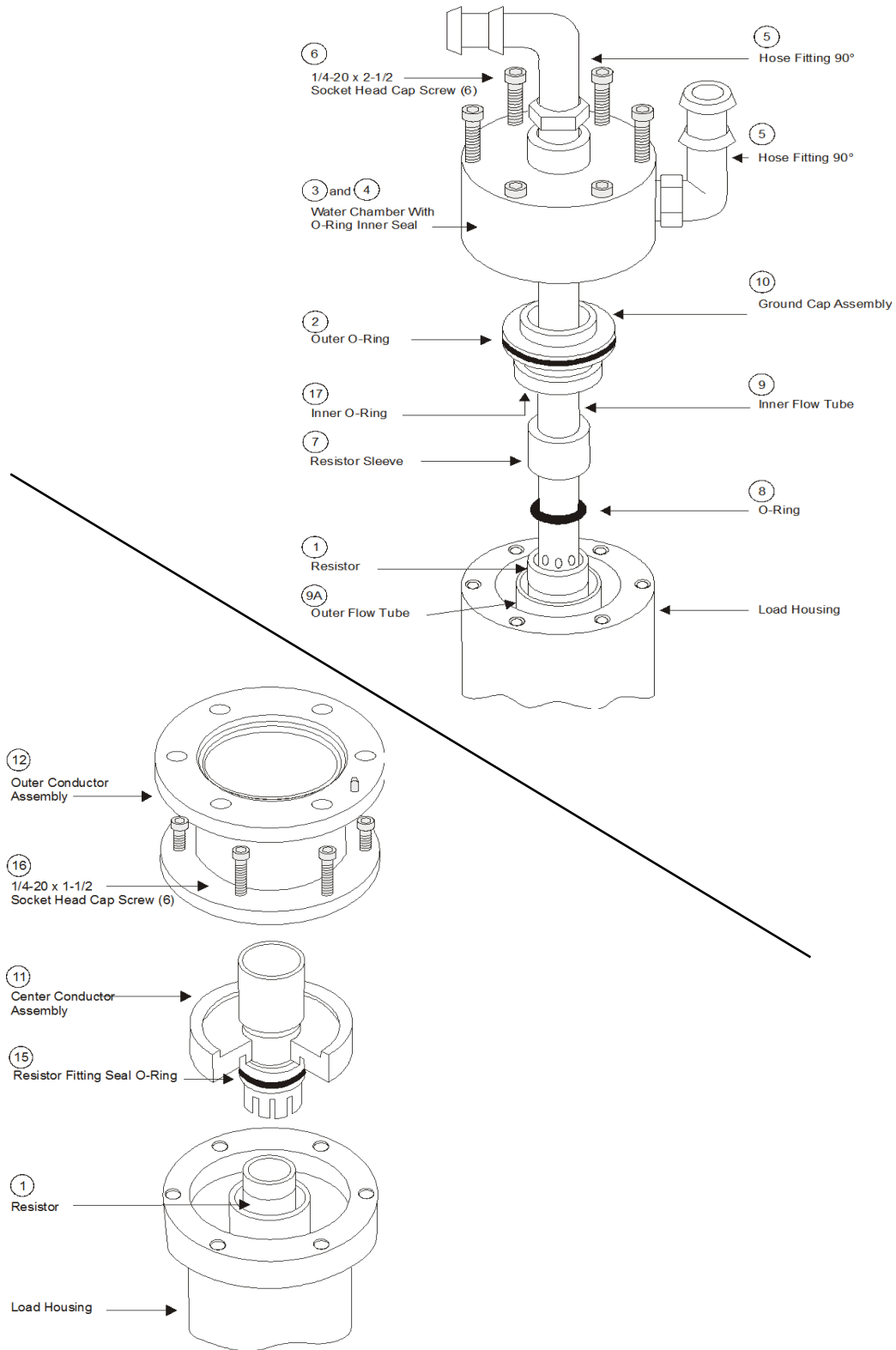

Replacement Parts Cont.

Description	Qty	Part Number
Casters	4	4421A384
Battery, size C, NiMH	8	5A1230
Cable, IEEE-488		
2 m	1	5-1317-2
1 m		5-1317-1
Cable, RS-232		
10 ft.	1	5-1662-2
5 ft.		5-1662-1
Null Modem Kit (RS-232 only)	1	4380-250
Panel Mount Kit	1	4421-250

LIMITED WARRANTY

All products manufactured by Seller are warranted to be free from defects in material and workmanship for a period of one (1) year, unless otherwise specified, from date of shipment and to conform to applicable specifications, drawings, blueprints and/or samples. Seller's sole obligation under these warranties shall be to issue credit, repair or replace any item or part thereof which is proved to be other than as warranted; no allowance shall be made for any labor charges of Buyer for replacement of parts, adjustment or repairs, or any other work, unless such charges are authorized in advance by Seller.

If Seller's products are claimed to be defective in material or workmanship or not to conform to specifications, drawings, blueprints and/or samples, Seller shall, upon prompt notice thereof, either examine the products where they are located or issue shipping instructions for return to Seller (transportation charges prepaid by Buyer). In the event any of our products are proved to be other than as warranted, transportation costs (cheapest way) to and from Seller's plant, will be borne by Seller and reimbursement or credit will be made for amounts so expended by Buyer. Every such claim for breach of these warranties shall be deemed to be waived by Buyer unless made in writing within ten days from the date of discovery of the defect.

The above warranties shall not extend to any products or parts thereof which have been subjected to any misuse or neglect, damaged by accident, rendered defective by reason of improper installation or by the performance of repairs or alterations outside of our plant, and shall not apply to any goods or parts thereof furnished by Buyer or acquired from others at Buyer's request and/or to Buyer's specifications. Routine (regularly required) calibration is not covered under this limited warranty. In addition, Seller's warranties do not extend to the failure of tubes, transistors, fuses and batteries, or to other equipment and parts manufactured by others except to the extent of the original manufacturer's warranty to Seller.

The obligations under the foregoing warranties are limited to the precise terms thereof. These warranties provide exclusive remedies, expressly in lieu of all other remedies including claims for special or consequential damages. SELLER NEITHER MAKES NOR ASSUMES ANY OTHER WARRANTY WHATSOEVER, WHETHER EXPRESS, STATUTORY, OR IMPLIED, INCLUDING WARRANTIES OF MERCHANTABILITY AND FITNESS, AND NO PERSON IS AUTHORIZED TO ASSUME FOR SELLER ANY OBLIGATION OR LIABILITY NOT STRICTLY IN ACCORDANCE WITH THE FOREGOING.

Special Lifetime Warranty - Series 4020, Series 4027A, Series 4027F, and Series 4028 Power Sensor Head

In addition to its standard warranty, the Bird Electronic Corporation warrants its Series 4020, Series 4027A, Series 4027F, and Series 4028 Thruline Power Sensor Heads for lifetime to original purchaser. This extended warranty is against burnout. For the warranty to apply, the Sensor Head must be used with the correct Bird Electronic Corporation Display Unit, the maximum power rating of the Sensor must not be exceeded, the Sensor RF circuit must be properly terminated and the Sensor not subjected to physical abuse.

Bird Electronic Corporation, at its option, will repair or replace the defective Sensor at its world Headquarters at 30303 Aurora Road, Solon, Ohio 44139.

The customer is responsible to pay transportation charges to return the defective sensor to Bird.