

INSTRUCTION BOOK FOR MODEL 4029 POWER SENSOR CALIBRATOR

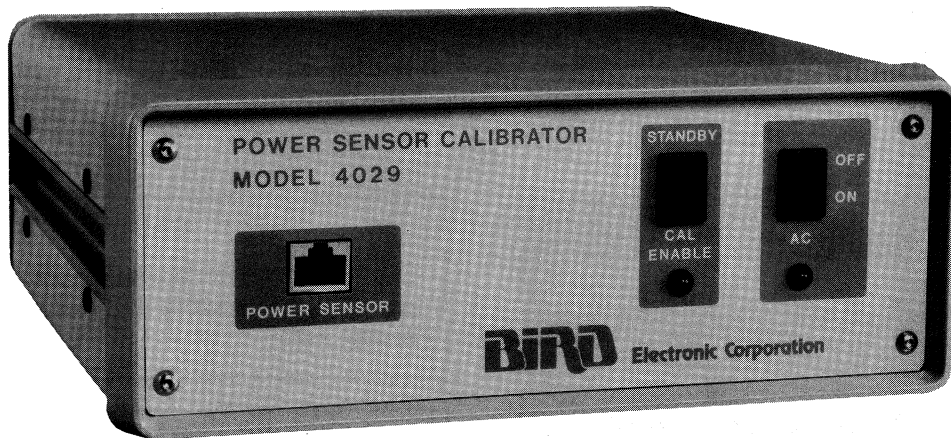

BIRD

Electronic Corporation

30303 Aurora Road, Cleveland, Ohio 44139-2794

© Copyright 1988 by Bird Electronic Corporation

SAFETY PRECAUTIONS

The following are general safety precautions that are not necessarily related to any specific part or procedure and do not necessarily appear elsewhere in this publication. These precautions must be thoroughly understood and apply to all phases of operation and maintenance.

KEEP AWAY FROM LIVE POWER: Keep parts of your body away from live circuits at all times. Serious injury or death can occur if this warning is not observed.

Operating personnel must at all times observe normal safety regulations. Do not attempt to replace components while power is applied. When working with high voltage, always have someone present who is capable of rendering aid, if necessary. Personnel working with or near high voltage should be familiar with modern methods of resuscitation.

SAFETY EARTH GROUND: An earth uninterruptible safety ground must be supplied from the main power source to the ac line module of the instrument. Grounding one conductor of a two conductor power cable is not sufficient protection. Serious injury or death can occur if this grounding is not properly supplied.

Warning: Warning notes call attention to a procedure, which if not correctly performed, could result in personal injury.

Caution: Caution notes call attention to a procedure, which if not correctly performed, could result in damage to the instrument.

The following precautions appear in the text of this publication and are shown here for emphasis.

WARNING

The potential for electrical shock exists. Always unplug the calibrator from the ac line before removing its cover.

WARNING

Never attempt to connect or disconnect the power sensor from the transmission line while RF power is being applied. Leaking RF energy is a potential health hazard.

WARNING

Provide adequate ventilation and observe normal precautions when using dry cleaning solvents. Many dry cleaning fluids emit toxic fumes that may be harmful to your health, if inhaled.

CAUTION

Do not apply RF power to the power sensor which exceeds 120% of full scale of the highest range.

CAUTION

The 4029 contains MOS (Metal Oxide Semiconductor) integrated circuits which can be damaged by static electricity. Open the enclosure only when sure that there are no static producing materials such as carpeting or styrofoam where the work is to be done. Work on a conductive, grounded work surface and touch it frequently to discharge static from your body. If a part is to be stored or shipped, wrap it in conductive packaging materials designed for static sensitive circuitry.

TABLE OF CONTENTS

Par.		Page
	SAFETY PRECAUTIONS	ii
	INTRODUCTION	
	Purpose and Function	1
	Capabilities	1
	SECTION I — DESCRIPTION	
1-1	General	2
1-3	Enclosure	2
1-5	Front Panel	3
1-6	Rear Panel	3
1-7	Internal Description	4
1-9	Dip Switch	4
	SECTION II — INSTALLATION	
2-1	General	6
2-3	Unpacking and Inspection	6
2-5	Installation	6
2-7	Line Voltage Connections	6
2-9	European Style Connectors	7
2-11	Serial CRT Terminal Connections	7
2-13	Communication Data Format Set Up	7
2-15	Power Sensor Calibration Set Up	8
	SECTION III — THEORY OF OPERATION	
3-1	General	10
3-3	Block Diagram Description	10
	SECTION IV — OPERATING INSTRUCTIONS	
4-1	General	11
4-3	Controls	11
4-5	Calibration Set-Up	11
4-7	Warm-Up Period	11
4-9	Calibration Power Level	11
4-11	Calibration Frequencies	11
4-13	Power Sensor Calibration	11
4-15	Power On Procedure	11
4-17	Power Up Display	12
4-19	Selecting the Calibration Direction	12
4-21	Viewing the Current Calibration Points	13
4-23	Adding a New Calibration Point	14
4-25	Deleting One Calibration Point	15
4-27	Removing All Calibration Points	16

SECTION V — MAINTENANCE

5-1	Preventive Maintenance	17
5-3	Error Statements	17
5-5	Calibration	17
5-7	Customer Service	17
5-10	Repackaging	18
5-12	Troubleshooting	18

SECTION VI — REPLACEMENT PARTS

6-1	General	19
6-3	Parts Illustration	19
6-5	Explanation of Columns	19

APPENDIX A — USING AN IBM COMPUTER AS A TERMINAL

A-1	General	21
A-3	Directions	21

ILLUSTRATIONS

Figure

1-1	Model 4029 Power Sensor Calibrator	2
1-2	Front Panel Layout	3
1-3	Rear Panel Layout	4
1-4	Dip Switch Assignments	4
1-5	Internal Layout	5
2-1	AC Line Module	6
2-2	Data Format Switches	7
2-3	Power Sensor Calibration Set-up	9
3-1	Block Diagram	10
4-1	Power Up Display	12
4-2	Displaying Current Calibration Points	13
4-3	Adding a Calibration Point	14
4-4	Removing One Calibration Point	15
4-5	Removing All Calibration Points	16
6-1	Exploded View of Calibrator	19
6-2	Printed Circuit Board	20
A-1	Terminal Program for IBM PC or XT computer	22

TABLES

Table

I-1	Specifications	1
1-1	RS-232 Lines Used By The Calibration	4
2-1	User Selectable Data Formats	8
4-1	Recommended Calibration Frequencies	11
5-1	Error Statements	17
6-1	Calibrator Parts List	20
6-2	PC Board Assembly Parts List	21

MODEL 4029 POWER SENSOR CALIBRATOR

INTRODUCTION

PURPOSE AND FUNCTION

This manual provides the information required for operating and maintaining the Bird Electronic Corporation Model 4029 Power Sensor Calibrator. It also serves as a guideline for calibrating 4020 series power sensors. Throughout this manual the Model 4029 will be referred to as the calibrator.

CAPABILITIES

The calibrator is an accessory for the 4420 series of Power Meters. It is a microprocessor-based instrument that is used for calibrating the 4020 Series RF Power Sensors. Each power sensor contains up to forty calibration factor vs. frequency points stored in non-volatile memory. The calibrator and an external CRT terminal (not supplied) provides access to the power sensor memory in order to add or delete individual calibration points, clear all calibration points, or simply list calibration points for review. The specifications for the calibrator are listed in Table I-1.

TABLE I-1. SPECIFICATIONS FOR MODEL 4029 POWER SENSOR CALIBRATOR

Calibration Transfer Accuracy	±2% of RF Power Standard Accuracy
Communications Baud Rates	Selectable. 50, 75, 110, 135, 150, 300, 600, 1200, 1800, 2400, 3600, 4800, 7200, 9600, and 19200 Baud.
Data Format	Asynchronous. 5, 6, 7, or 8 data bits, 1 or 2 stop bits selectable.
Data Code	ASCII Standard
AC Power	115 or 230 Vac ±10%, 45-66Hz. 9.0 Va.
Fuse	3AG 0.15A 250V
EMI Compliance	Exceeds FCC Class A requirements for computing devices. (Both radiated and conducted emission.)
Temperature Range	
Operating	+20°C to +30°C (68°F to 86°F)
Storage	-10°C to +70°C (14°F to 158°F)
Dimensions	10 ⁵ / ₁₆ " L × 10 ¹ / ₈ " W × 4 ¹ / ₄ " D (262mm × 257mm × 108mm)
Weight	5 ¹ / ₄ lb. (2.4kg)

ADDITIONAL EQUIPMENT REQUIRED BUT NOT SUPPLIED

The following equipment is required to calibrate 4020 Series RF Power Sensors but is not supplied with the calibrator.

- a. **Serial CRT Terminal** — A serial terminal is used to transfer information between the calibrator and the user. It must be compatible with an RS-232 format for standard communications of ASCII coded data. The calibrator has selectable data format and baud rates to match most serial terminals. (Refer to Table 2-1). All data is displayed in a standard 24 lines by 80 columns format. Most personal computers can be configured as a serial terminal. Appendix A contains a program that allows an IBM PC computer to be used as a terminal.
- b. **RF Power Source** — A RF Power Source provides the reference power level to the power sensor during calibration. It must be capable of producing stable CW power into 50 ohms at all of the calibrating frequencies. Each harmonic of the RF signal must be at least 50 db less than the fundamental signal. Any residual amplitude modulation must be less than 0.5%. The above requirements can be easily achieved by using a combination of a signal generator and a broad band power amplifier with proper filtering.
- c. **RF Power Meter Standard** — The power meter standard is used to accurately measure the CW power applied to the power sensor during calibration. The calibrator transfers the accuracy of the power meter standard to the power sensor. The accuracy of final calibration is highly dependent on the accuracy of the power meter standard. Aside from being accurate, it must also be able to operate over the frequency range and power level of the RF power source. Input SWR should be low to keep mismatch errors to a minimum.
- d. **Serial Communication Cable** — A 25 conductor serial communications cable is used to connect the calibrator to the serial CRT terminal. The calibrator end should be serviced with a Standard DB25 (25 pin male "D") connector. The terminal end should be serviced with a connector to mate with the serial output port of your terminal. Consult your terminal manual for the correct connector configuration. Bird Electronic Corporation offers two different lengths of cable assemblies for use with the calibrator (P/N 5-1662-1, 5 feet or 5-1662-2, 10 feet).

SECTION I — DESCRIPTION

1-1. GENERAL

1-2. The Model 4029 Power Sensor Calibrator is a microprocessor based instrument that is used to calibrate 4020 Series RF Power Sensors. This section provides an overall description of the calibrator and its front and rear panel features.

1-3. ENCLOSURE

1-4. The calibrator is contained within an aluminum enclosure. (See Figure 1-1). Its front and rear panels are recessed to avoid accidental damage to panel mounted hardware. The instrument is completely portable but is designed for bench top use.

FIGURE 1-1. MODEL 4029 POWER SENSOR CALIBRATOR.

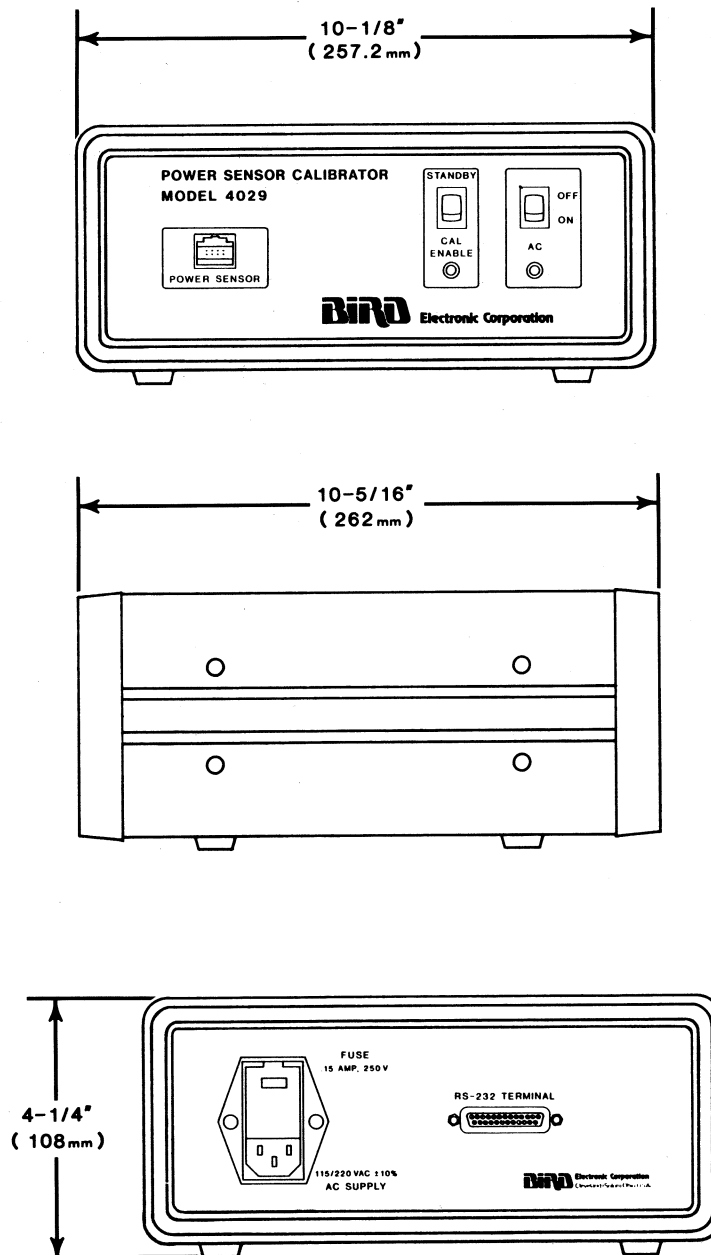

1-5. FRONT PANEL

The front panel features of the calibrator are shown in Figure 1-2. The following is a description of the connectors, controls and indicator lamps.

- a. AC ON/OFF Switch — The front panel AC ON/OFF switch controls the AC line power to the calibrator circuits.
- b. AC Lamp — This red lamp will light to indicate that AC power is being applied to the calibrator circuits.
- c. CAL ENABLE/STANDBY Switch — Changes in Power Sensor calibration are prevented when this switch is in the STANDBY position. During power

sensor calibration, the switch is placed in the CAL ENABLE position.

- d. CAL ENABLE Lamp — The green CAL ENABLE lamp lights when the CAL ENABLE/STANDBY switch is in the CAL ENABLE position. This provides a visual indication that the calibrator is able to make changes in the power sensor calibration data.

- e. POWER SENSOR Connector — The latch-n-lock power sensor connector provides a means for connecting the calibrator to the power sensor under test. This connection is made using the sensor cable (P/N 4421-038)

FIGURE 1-2. FRONT PANEL LAYOUT.

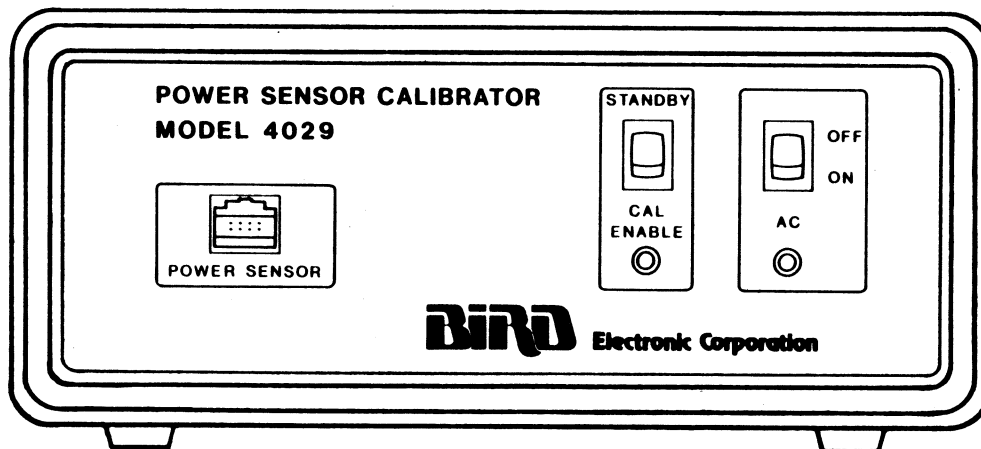

1-6. REAR PANEL

The rear panel features of the calibrator are shown in Figure 1-3. The following is a description of the major components on the rear panel.

- a. AC Line Module — The AC line module contains the line socket for input of AC power. It also houses the line voltage selector and the AC line fuse. Detailed instructions for selecting the proper line voltage and changing the AC fuse are contained in the installation section.

- b. RS-232 Terminal Connector — This 25 pin "D" type connector provides for connection of the serial terminal to the calibrator. The pin assignments, physical parameters and electrical specifications meet the RS-232 interface standard of data communications. The pins which are used by the calibrator appear in Table 1-1. In cases where the terminal employs a slightly different wiring arrangement, no attempt should be made to rewire this connector. Bird offers a null modem kit, P/N 4380-250 which can be used to rearrange the lines separate from the calibrator.

FIGURE 1-3. REAR PANEL LAYOUT.

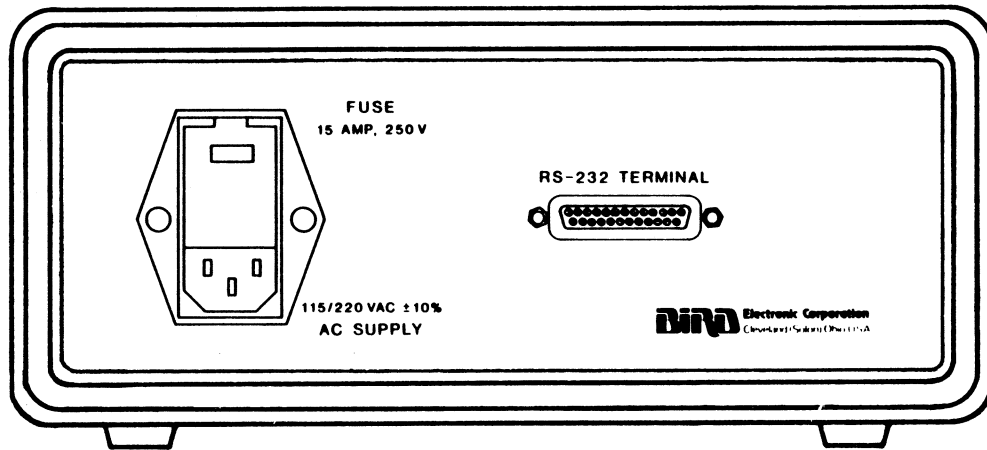

TABLE 1-1. RS-232 LINES USED BY THE CALIBRATOR.

Pin No.	Signal Name	Source	Function
2	TD (BA)	4029	Transmit Data
3	RD (BB)	Terminal	Receive Data
4	RTS (CA)	4029	Request To Send Internally held true
5	CTS (CB)	4029	Clear to Send Internally held true
6	DSR (CC)	4029	Data Set Read Internally held true
7	SG (AB)	None	Ground for Data and Control signals
20	DTR (CD)	4029	Data terminal ready Internally held true

1-7. INTERNAL DESCRIPTION

WARNING

The potential for electrical shock exists. Always unplug the calibrator from the ac line before removing its cover.

1-8. Figure 1-5 is a top view of the calibrator with its cover removed. This internal view shows the location of the DIP Switch and DTE/DCE Switch.

1-9. DIP SWITCH

1-10. The internal eight station DIP switch controls the data format and baud rate of the calibrator. The general switch assignments are shown in Figure 1-4. The available settings are listed in Table 2-1. The factory set default conditions for the calibrator are:

- 9600 Baud
- 8 data bits
- 1 stop bit

FIGURE 1-4. DIP SWITCH ASSIGNMENTS.

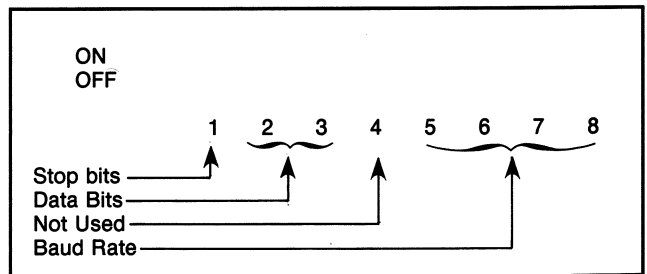

DTE/DCE Switch — When this switch is in the DTE position, the calibrator is configured as a Data Terminal Equipment and appears as a host computer to the terminal. With the switch in the DCE position, the calibrator is configured as Data Communications Equipment and looks like a modem to the terminal.

FIGURE 1-5. INTERNAL LAYOUT.

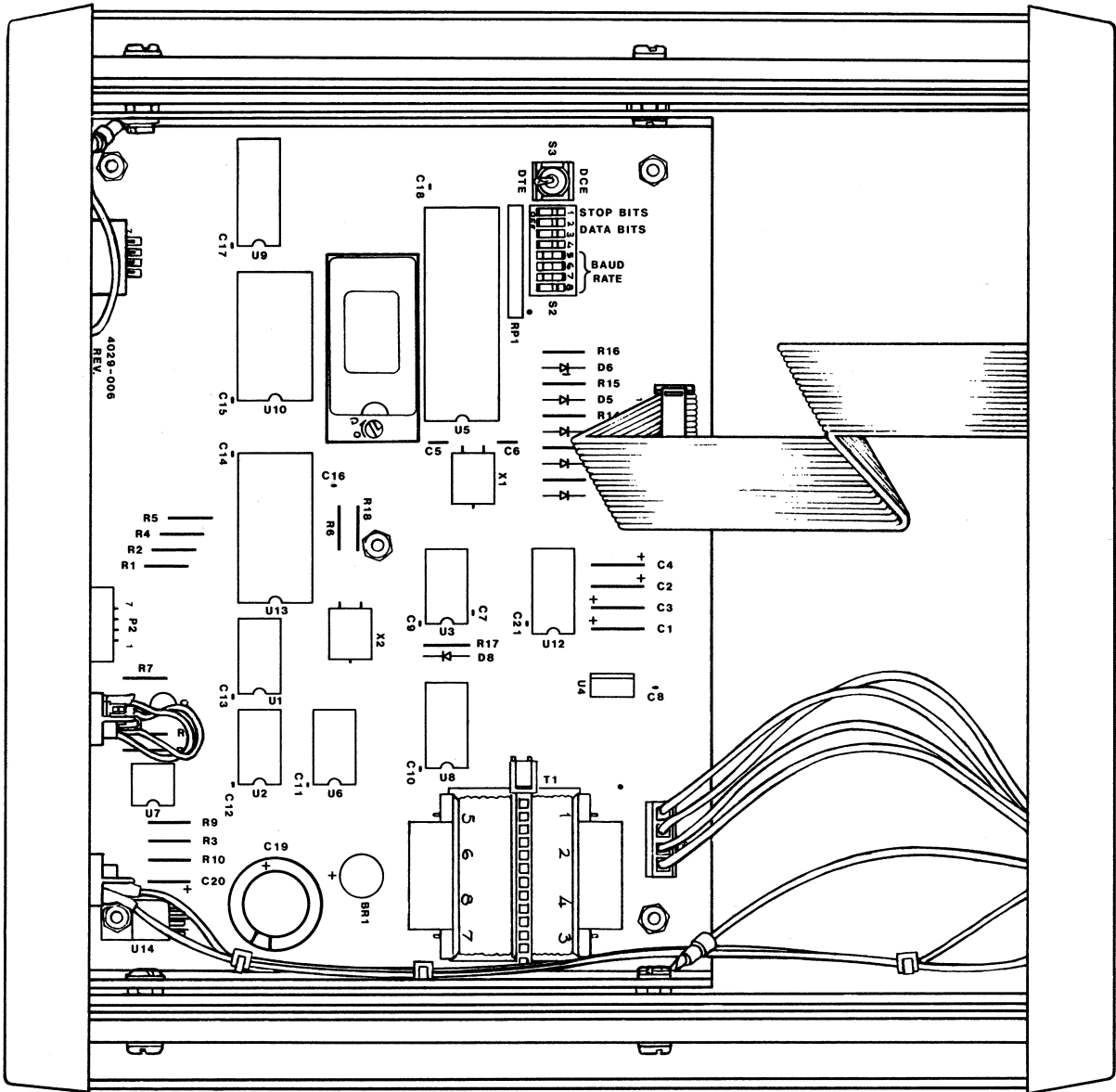

SECTION II — INSTALLATION

2-1. GENERAL

2-2. The calibrator is intended for bench top use in a laboratory environment. This section provides all of the information necessary to unpack, inspect, and install the calibrator.

2-3. UNPACKING AND INSPECTION

2-4. The Model 4029 Power Sensor Calibrator is shipped in a single container. Included in the container are:

- 1 Power Sensor Calibrator
- 1 AC Power Cord
- 1 Instruction Manual

All packages are carefully wrapped and inspected at Bird prior to shipment. If the shipping container shows any sign of damage, open the package and inspect the instrument. Immediately notify the carrier if any damage is visible. Retain the shipping container and all packing material for the carrier's inspection. Keep all packing material for storage or reshipment of the calibrator.

2-5. INSTALLATION

2-6. The following paragraphs describe, in step-by-step fashion, how to prepare the calibrator for

use. These procedures should be thoroughly understood before proceeding to the Operation Section.

2-7. LINE VOLTAGE CONNECTORS

2-8. The calibrator can be powered with 115 or 230 Vac $\pm 10\%$ at 45 to 66Hz. The following procedure explains how to set the calibrator to operate from the available line voltage.

- a. Place the calibrator on a clean, flat work surface with the rear panel facing you.
- b. Determine if the available line voltage is 115 or 230 Vac.
- c. Compare the available voltage with the voltage value that appears in the line select window. (See Figure 2-1) The calibrator is set at the factory for 115 Vac operation.
- d. For 230 Vac operation, pry open the cover door and remove the voltage selector drum. Rotate the drum until it indicates 230 Vac and then reinsert.
- e. Check for proper AC line fuse by sliding the fuse drawer out. The fuse should be a 3AG 0.15A 250V type. Reinstall the fuse drawer.
- f. Close the cover door.

Complete the line voltage connection by inserting the modular ac power cord plug into the receptacle on the ac line module.

FIGURE 2-1. AC LINE MODULE.

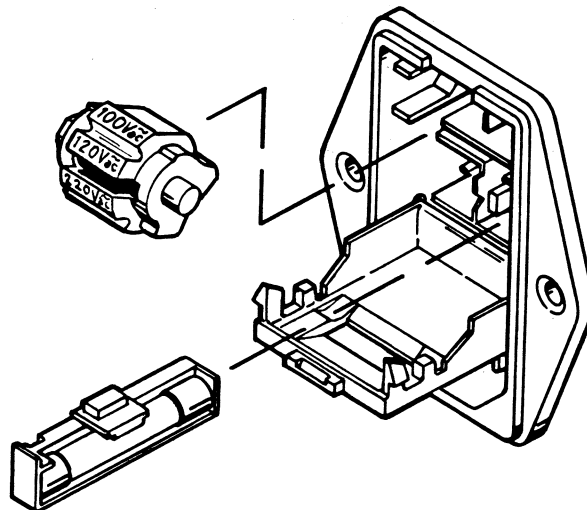

2-9. EUROPEAN STYLE CONNECTORS

2-10. To make the ac power cord compatible with European style sockets, the user must replace the connector at the end of the power cord. Then set the voltage selector drum for 230 Vac operation.

2-11. SERIAL CRT TERMINAL CONNECTIONS

2-12. The serial terminal is connected to the calibrator through a 25 pin conductor cable equipped with DB25 connectors. These cables can be purchased from Bird in one of two lengths (P/N 5-1662-1, 5 feet or 5-1662-2, 10 feet). Two screws are located on each connector to ensure that the connections remain secure. The following procedure explains how to connect a serial CRT terminal to the calibrator.

- Line up the cable connector with the RS-232 Terminal connector located on the rear panel of the calibrator. The connector is designed so that it will fit only one way.
- Tighten the connector screws securely. Do not overtighten.
- Line up the cable connector with the serial port on the terminal. Most terminals are equipped for use with DB25 style connectors. Consult the instruction manual for your terminal for the proper connecting method.
- Tighten the connector screws securely. Do not overtighten.

2-13. COMMUNICATION DATA FORMAT SET-UP

2-14. Inside the calibrator are DIP switches that control the data format and baud rate of the serial communication. These switches are factory set for 9600 baud, 8 data bits, and 1 stop bit. For proper operation, the switches must be set to match the data format and baud rate of the user's terminal. The following procedure explains how to set these switches.

WARNING

The potential for electrical shock exists. Always unplug the calibrator from the ac line before removing its cover.

- Remove the four screws that secure the top cover to the calibrator. Remove the top cover by pulling straight up.
- Locate the DIP switch, S3 and the DTE/DCE switch, S2 (see Figure 2-2).
- The proper switch settings for use with your terminal can be found in Table 2-1. Use a pencil or similar object to place the switches in their correct positions.
- Determine whether the terminal is operating as Data Terminal Equipment (DTE) or Data Communication Equipment (DCE). If the terminal is data terminal equipment, place the toggle switch, S3, in the DCE position. The toggle switch should be placed in the DTE position if the terminal is data communications equipment.
- Install the top cover onto the calibrator. Secure with four screws.

FIGURE 2-2. DATA FORMAT SWITCHES.

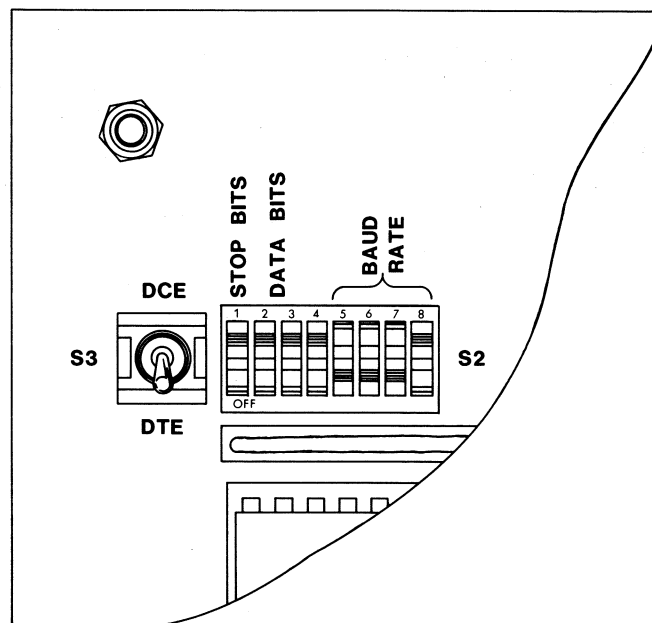

TABLE 2-1. USER SELECTABLE DATA FORMATS.

Switch No.	Function	Setting
1	Stop Bit	ON = 2 stop bits (1½ stop bits for 5 data bits) OFF = 1 stop bit *
2 3	Data Bits	SW2 SW3 ON ON = 5 data bits * ON OFF = 6 data bits OFF ON = 7 data bits OFF OFF = 8 data bits
4	Not used	Not used
5 6 7 8	Baud Rate	SW5 SW6 SW7 SW8 Baud Rate OFF OFF OFF ON 50 OFF OFF ON OFF 75 OFF OFF ON ON 110 OFF ON OFF OFF 135 OFF ON OFF ON 150 OFF ON ON OFF 300 OFF ON ON ON 600 ON OFF OFF OFF 1200 ON OFF OFF ON 1800 ON OFF ON OFF 2400 ON OFF ON ON 3600 ON ON OFF OFF 4800 ON ON OFF ON 7200 ON ON ON OFF 9600 * ON ON ON ON 19200
*Factory-set default condition		

2-15. POWER SENSOR CALIBRATION SET-UP

2-16. A typical set-up for power sensor calibration is illustrated in Figure 2-3. Special precautions must be taken to prevent the set-up from introducing calibration errors. The following procedure explains the proper methods of connecting the equipment for power sensor calibration.

- a. Connect the calibrator to the CRT terminal by following the instructions of Paragraph 2-11.
- b. Connect the power sensor to the calibrator using the sensor cable, P/N 4421-038. Insert the cable plug so that the latching mechanism aligns with the groove in the Power Sensor Connector. Apply a minimum amount of pressure until the latch mechanism locks into position. Repeat the same procedure to connect the other end of the sensor cable to the power sensor.

WARNING

Never attempt to connect or disconnect the power sensor from the transmission line while RF power is being applied. Leaking RF energy is a potential health hazard.

- c. Install the power sensor between the RF power source and the power meter standard. The Series 4020 are directional power sensors and must be calibrated in both the forward and reflected directions. In order to perform the forward power calibration, the power sensor is installed with its arrow pointing towards the power standard (as shown in Figure 2-3.) For reflected calibration, the power sensor is turned around so that the arrow points toward the power source. The connection between the power sensor and the RF power standard must be kept as short as possible to reduce errors associated with insertion loss. The connectors themselves must be kept free of dirt and grime and should be periodically inspected for wear.

FIGURE 2-3. POWER SENSOR CALIBRATION SET-UP.

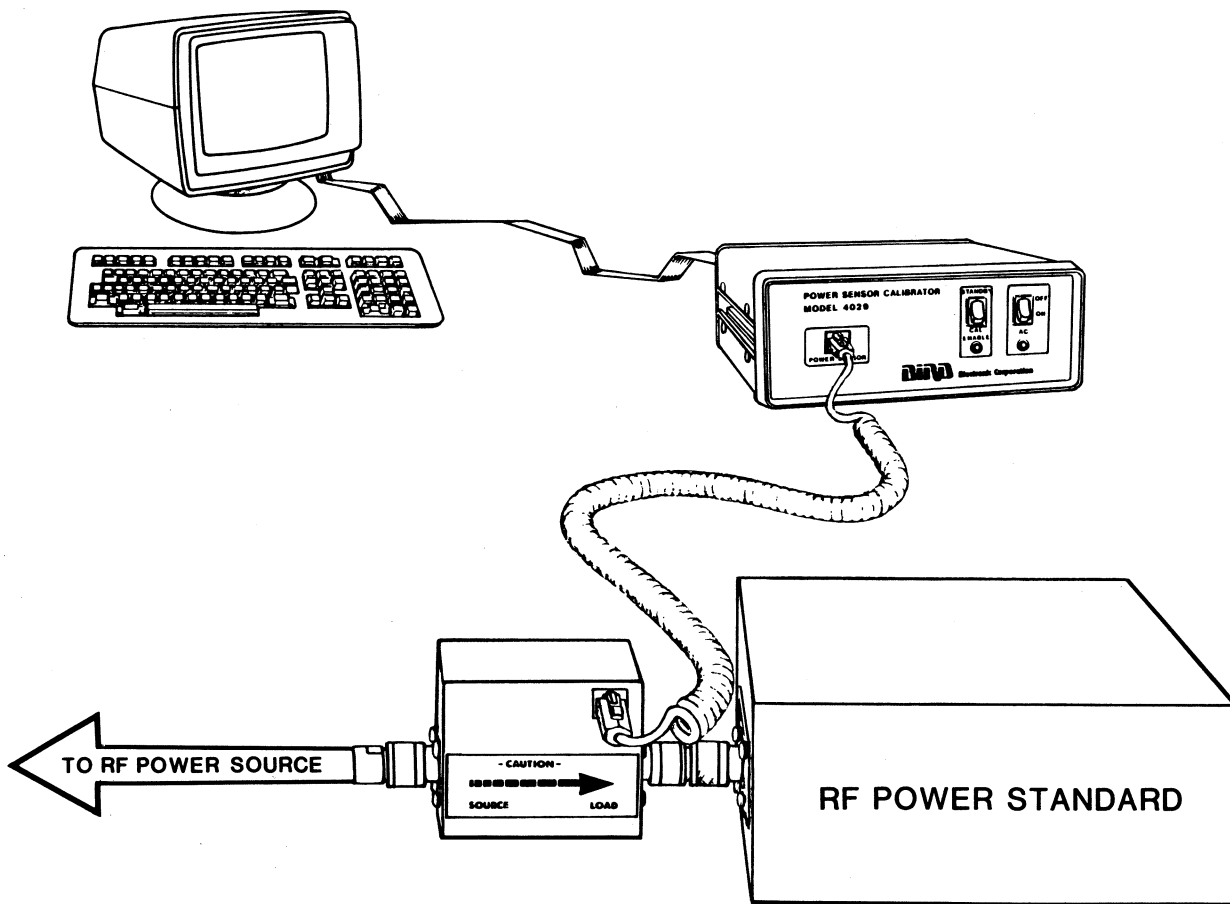

SECTION III — THEORY OF OPERATION

3-1. GENERAL

3-2. The 4029 Power Sensor Calibrator is a microprocessor based interface device used to calibrate 4020 Series Power Sensors. During calibration, correction factors are stored in the power sensors non volatile memory. The power sensor uses this table of calibration factor versus frequency to correct the power measurements. With the use of the calibrator, a person can add to or delete all or part of the correction table. A general theory of the calibrators operation is given in this section. It is intended to familiarize the user with its operation so that a better understanding of power sensor calibration is possible.

3-3. BLOCK DIAGRAM DESCRIPTION

3-4. A general block diagram of the calibrator is illustrated in Figure 3-1. Refer to this diagram throughout the following discussion.

3-5. The Power Sensor is the device that is being calibrated. During calibration, a precisely known amount of RF power at a particular frequency is applied to the power sensor. The user follows prompts that appear on the CRT terminal and enters the value

of the power. The serial interface controls all of the communication between the CRT terminal and the controller.

3-6. The controller performs a series of instruction that are stored in read only memory (ROM) and instructs the power sensor under test to measure the RF power and frequency. Data is transferred over the power sensor cable using a serial data format. The power measured by the power sensor is compared to the correct power value entered through the CRT terminal and a correction factor is determined. The correction factor is stored in non volatile memory in the power sensor along with the frequency at which the factor was determined. This procedure is repeated for as many as twenty separate frequencies for each direction of power flow.

3-7. The calibration enable circuit monitors the power supply circuits and prevents erroneous changes in calibration data when the calibrator is switched off. The CAL ENABLE/STANDBY switch can be manually set to prevent accidental calibration changes.

3-8. All of the voltages needed by the calibrator and the power sensor under test are generated by the power supply circuits.

FIGURE 3-1. BLOCK DIAGRAM.

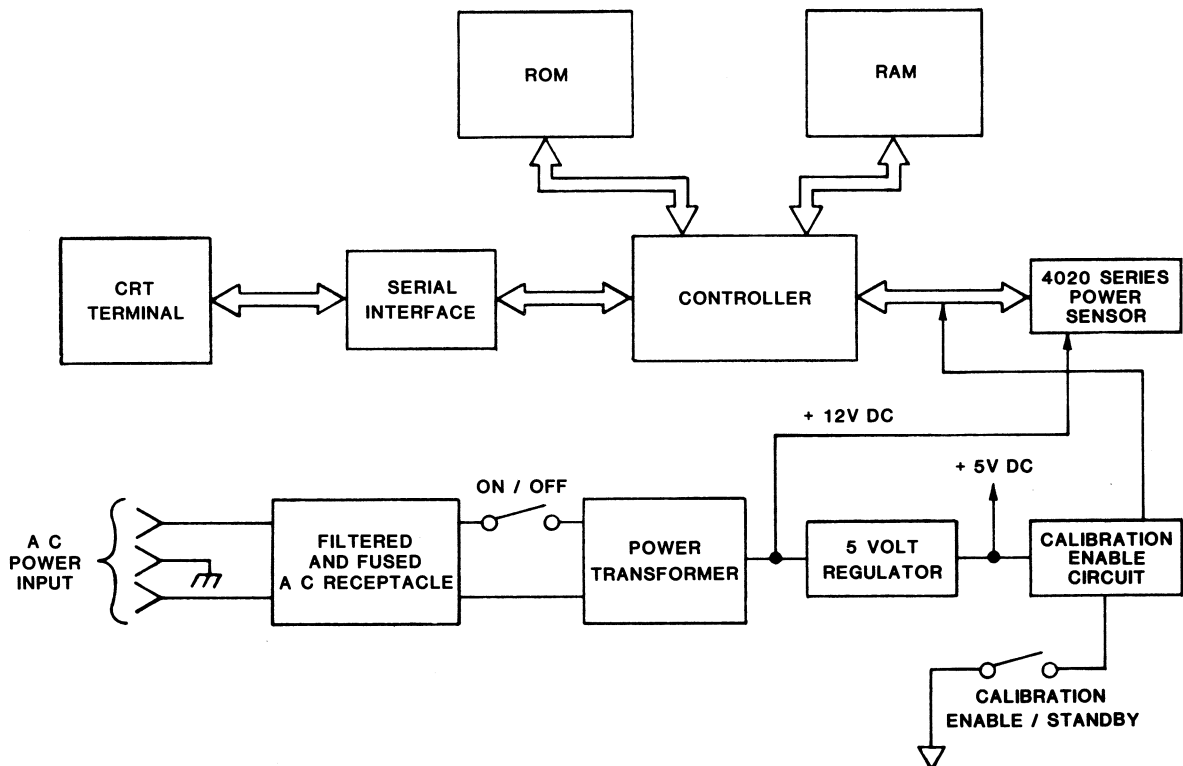

SECTION IV — OPERATING INSTRUCTIONS

4-1. GENERAL

4-2. This section details the proper method of operating the Model 4029 Power Sensor Calibrator. It can also be used as a guideline for calibrating 4020 series power sensors. Step by step examples of power sensor calibration are used to demonstrate operation of the calibrator.

4-3. CONTROLS

4-4. The calibrator has two front panel controls that are used during its operation. The ON/OFF switch controls the application of ac line power to the calibrator circuits. The CAL ENABLE/STANDBY switch provides a standby mode in which power sensor calibration can be viewed without accidentally changing the stored data. Therefore, the CAL ENABLE mode must be selected to make changes to the power sensor calibration data.

4-5. CALIBRATION SET-UP

4-6. A complete procedure for power sensor calibration set up is detailed in Paragraph 2-15 of the Installation Section.

4-7. WARM-UP PERIOD

4-8. The calibrator does not require a warm up period. It will function properly as soon as it is switched on. However, the Series 4020 Power Sensors must be at a stabilized ambient room temperature for at least one hour prior to calibrating.

4-9. CALIBRATION POWER LEVEL

CAUTION

Do not apply RF power to the power sensor which exceeds 120% of full scale of the highest range.

4-10. The Series 4020 Power Sensors are capable of being calibrated at any power level within their operating power range. This is due to the linear detection scheme used in the power sensors. The calibration power level of ten watts will be used for the examples in this section. Regardless of which power level is used, it is important to ensure that the calibration power is stable.

4-11. CALIBRATION FREQUENCIES

4-12. A calibration point can be added at any frequency within the limits of the power sensor's bandwidth. However, to maintain the specified accuracy, Bird recommends calibrating power sensors at the frequencies listed in Table 4-1. These frequencies have been selected to ensure minimum interpolation errors between calibration points.

TABLE 4-1. RECOMMENDED CALIBRATION FREQUENCIES.

Model 4021	Model 4022	Model 4024
1.8 MHz	25 MHz	1.5 MHz
2.0 MHz	30 MHz	1.8 MHz
2.5 MHz	40 MHz	7.0 MHz
3.2 MHz	50 MHz	7.5 MHz
4.0 MHz	70 MHz	3.2 MHz
5.0 MHz	90 MHz	4.0 MHz
6.3 MHz	150 MHz	5.0 MHz
7.9 MHz	270 MHz	6.3 MHz
10.0 MHz	400 MHz	7.9 MHz
13.0 MHz	500 MHz	10.0 MHz
16.0 MHz	600 MHz	13.56 MHz
20.0 MHz	710 MHz	16.0 MHz
25.0 MHz	750 MHz	20.0 MHz
32.0 MHz	800 MHz	25.0 MHz
	900 MHz	32.0 MHz
	950 MHz	
	1000 MHz	

4-13. POWER SENSOR CALIBRATION

NOTE: Bird Electronic Corporation cannot guarantee the accuracy of Series 4020 Power Sensors that have been calibrated at other than factory authorized service centers. Therefore, using the 4029 to change power sensor calibration will void the power sensor calibration warranty.

4-14. The following examples of power sensor calibration are used to demonstrate operation of the calibrator. The related figures are used to illustrate the menu and prompts that are displayed on the terminal CRT.

4-15. POWER ON PROCEDURE

4-16. Set up of the calibrator is described in Installation Section II. Be sure that the voltage selector drum in the ac line module is set to match the available line voltage. Set the CAL ENABLE/STANDBY switch to the STANDBY position. Place the ON/OFF switch to the on position. The red ac lamp should light to show that the calibrator is on. If the lamp does not light, refer to the maintenance section for possible faults.

4-17. POWER UP DISPLAY

4-18. Refer to Figure 4-1 for an illustration of the power up display. The top portion of the display contains the instrument software identifier and revision date. The menu below, offers a choice of six functions that can be performed by the calibrator. A function is selected by entering the number (one thru six) via the terminal followed by the RETURN key.

4-19. SELECTING THE CALIBRATION DIRECTION

4-20. The Series 4020 are directional power sensors that provide information about the RF power flowing in both the forward and reflected directions. Calibration of these sensors must therefore be per-

formed in both directions. The menu functions numbers "1" and "2" are used to select the forward or reflected power calibration. The current direction of calibration is indicated by the direction statement above the menu. The calibrator will always be in the FORWARD power calibration mode upon power up. To select the reflected power calibration, enter the number "2" followed by RETURN. See Figure 4-1. The calibrator will display "REFLECTED calibration selected" followed by the menu. The direction indicator above the menu will indicate that the reflected power calibration has been selected. During calibration of a power sensor, the direction of power through the sensor must match the direction statement. To return to forward power calibration simply use the "Select Forward power calibration" function.

FIGURE 4-1. POWER UP DISPLAY.

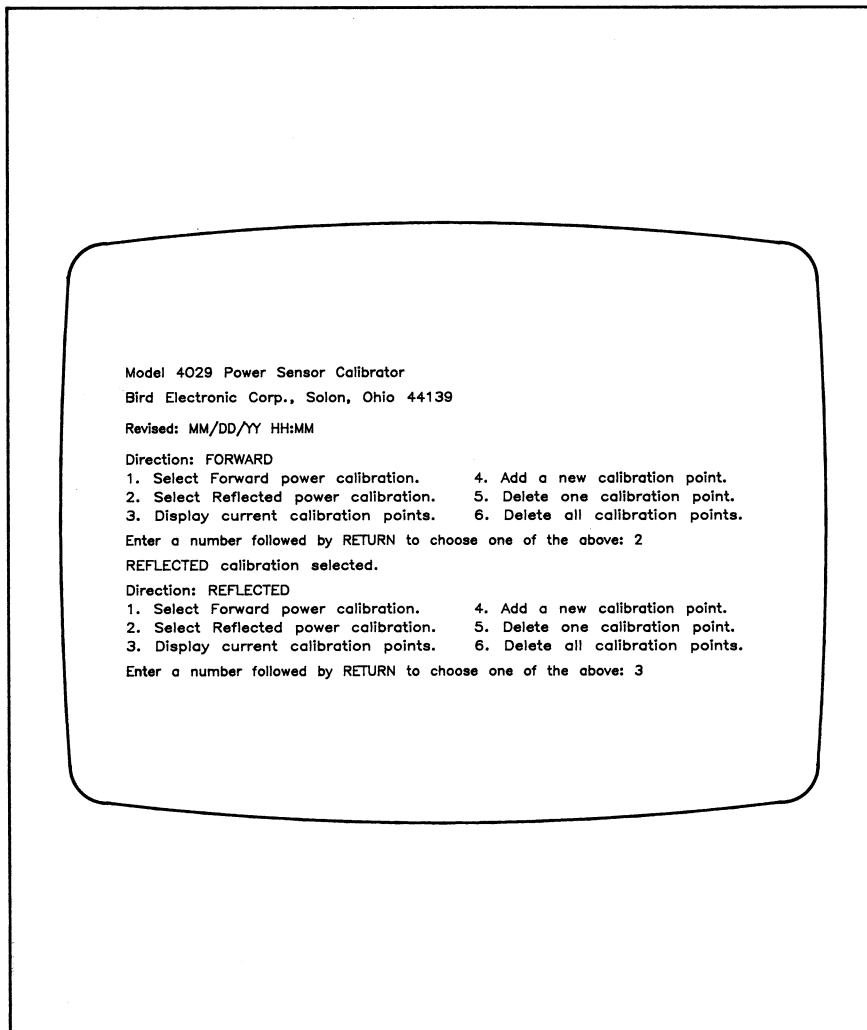

4-21. VIEWING THE CURRENT CALIBRATION POINTS

4-22. The calibration factors stored in the power sensor can be viewed by using the "Display current calibration points." function. To view the calibration data, enter the number "3" followed by RETURN. Figure 4-2 shows a typical display of calibration points for a Model 4021 Power Sensor. The DIRECTION indicator shows that these calibration points are in the reflected calibration memory. The current frequency is displayed in the upper right hand corner of the screen. Calibration points are numbered 1 thru

20 in ascending order of RF frequency. If a new point is added it will be fit into the table according to its frequency and all other points will be renumbered. If a point is removed, the remaining higher frequency points will each decrease in point number by one. The frequency column indicates the RF frequency (in MHz) that was measured by the power sensor at each calibration point. The Low Factor, High Factor columns lists the actual calibration factors that are used to correct the power measurement. It should be noted that the High Factors in the Model 4021 and 4024 Power Sensors will always be 1.00. To return to the menu, press the RETURN key.

FIGURE 4-2. DISPLAYING CURRENT CALIBRATION POINTS.

Direction: Point #	REFLECTED Frequency, MHz.	Current Frequency: Low Factor	.0000 MHz. High Factor
1	1.8	15.73	1.00
2	2.0	15.71	1.00
3	2.5	15.68	1.00
4	3.2	15.64	1.00
5	4.0	15.60	1.00
6	5.0	15.56	1.00
7	6.3	15.53	1.00
8	7.9	15.52	1.00
9	10.0	15.50	1.00
10	13.0	15.48	1.00
11	16.0	15.49	1.00
12	20.0	15.54	1.00
13	32.0	15.73	1.00

Press RETURN key to continue...:

4-23. ADDING A NEW CALIBRATION POINT

CAUTION

Do not apply RF power to the power sensor which exceeds 120% of full scale of the highest range.

4-24. A new calibration point can be added to a power sensor by using the "Add a new calibration point" function. Enter number "4" followed by return to add a calibration point. The CAL ENABLE/STANDBY switch must be placed in the CAL ENABLE position to allow calibration. The calibrator provides

instruction on adding a new point as illustrated in Figure 4-3. First, the RF source is adjusted to the desired calibration frequency. The calibrating power is then applied to the input of the power sensor and measured by the RF power standard at the output of the power sensor. The measured power level is entered followed by the RETURN key. The calibrator will measure the RF frequency, calculate and store the new calibration point, and then display, "A new calibration point has been added at XX.XMHz". A calibration point number will be assigned and all the other existing calibration point numbers will be automatically adjusted. If it is necessary to return to the menu without adding a new calibration point, press RETURN without entering a power level.

FIGURE 4-3. ADDING A CALIBRATION POINT.

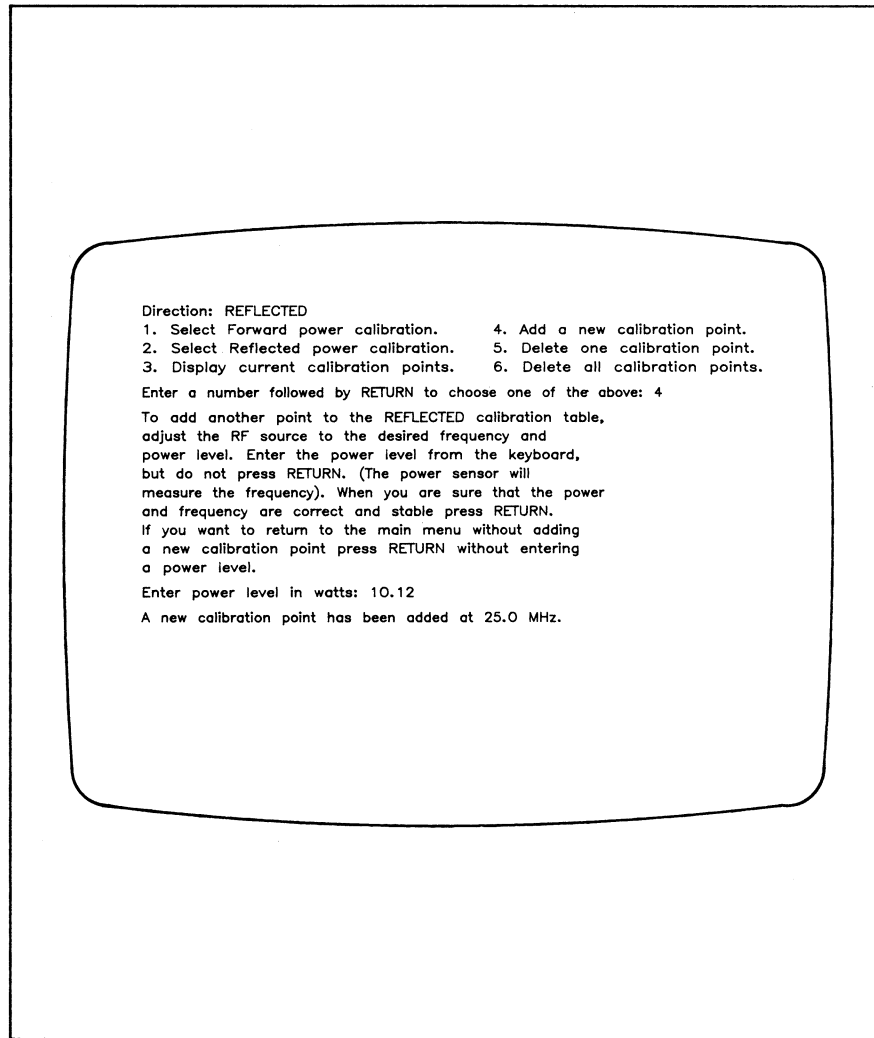

4-25. DELETING ONE CALIBRATION POINT

4-26. It sometimes becomes necessary to remove the calibration point at one frequency. This can be performed using the "Delete one calibration point." function. An example of this procedure is explained below and illustrated in Figure 4-4. Let us assume that the calibration point at 25MHz was found to be incorrect. This point must be removed before adding a new 25MHz calibration point. First, the calibration point number at 25MHz must be determined. This is done using the "Display current calibration points."

function. (See Paragraph 4-21). Once the point number is found, select the "Delete one calibration point." function. The display prompts you to enter the number of the calibration point to be deleted. Enter the point number that corresponds to the 25MHz calibration point and press the RETURN key. The display will indicate "Calibration point number X has been removed." Use the "Display current calibration points" function to verify that the point has been removed. To return to the menu without removing a calibration point, simply press the RETURN key without entering a point number.

FIGURE 4-4. REMOVING ONE CALIBRATION POINT.

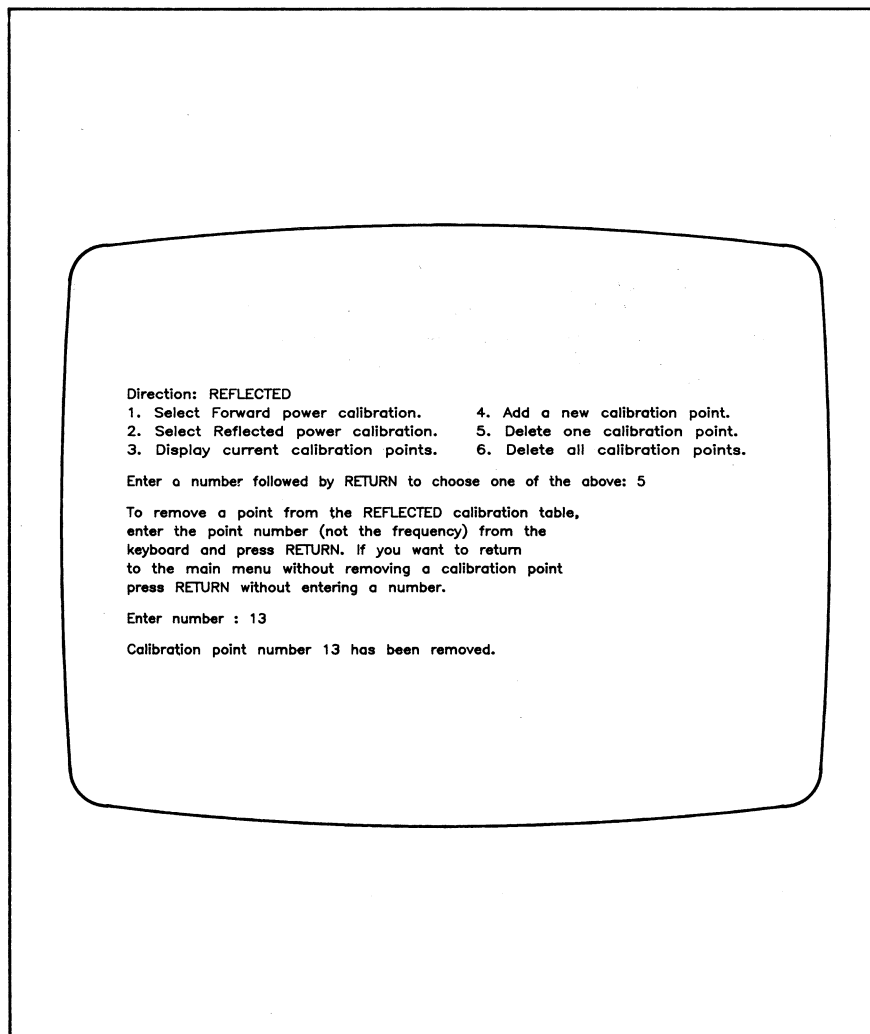

4-27. REMOVING ALL CALIBRATION POINTS

4-28. All of the calibration points must be deleted before performing a complete power sensor recalibration. This can be done with the "Delete all calibration points" function. To remove all points enter number "6" followed by RETURN. Refer to

Figure 4-5. The calibrator requires that you enter "Y" followed by RETURN to clear all of the data points. To return to the menu without clearing the data points, enter "N" followed by RETURN. The data points are removed only in the calibration direction that is selected.

FIGURE 4-5. REMOVING ALL CALIBRATION POINTS.

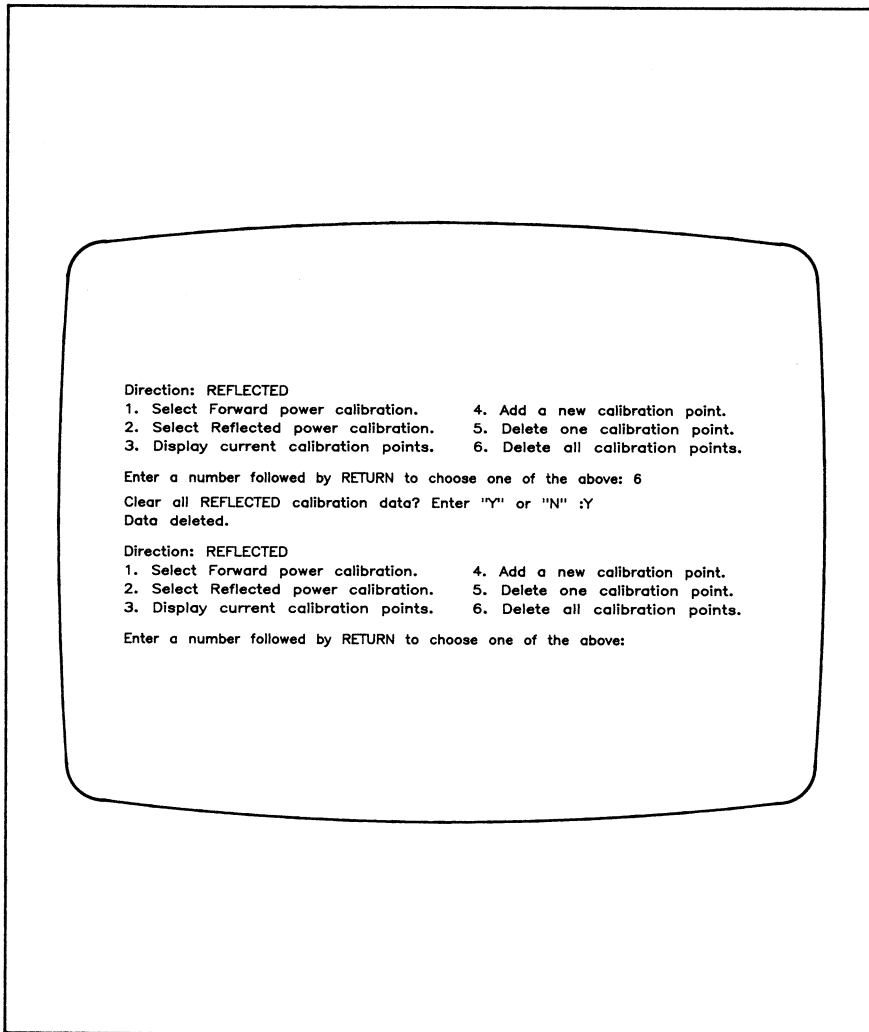

SECTION V — MAINTENANCE

5-1. PREVENTIVE MAINTENANCE

WARNING

Provide adequate ventilation and observe normal precautions when using dry cleaning solvents. Many dry cleaning fluids emit toxic fumes that may be harmful to your health, if inhaled.

CAUTION

The 4029 contains MOS (Metal Oxide Semiconductor) integrated circuits which can be damaged by static electricity. Open the enclosure only when sure that there are no static producing materials such as carpeting or styrofoam where the work is to be done. Work on a conductive, grounded work surface and touch it frequently to discharge static from your body. If a part is to be stored or shipped, wrap it in conductive packaging materials designed for static sensitive circuitry.

5-2. The calibrator requires only basic routine maintenance. Store the calibrator in a clean environment when not in use.

a. Cleaning

Periodically clean the front panel housing using a clean soft cloth. Gently remove any dirt or grime from the power sensor connector using a cotton swab that has been moistened with an acceptable dry cleaning solvent.

b. Inspection

A general inspection of the calibrator should be performed every six months. Carefully inspect the power sensor connector and the terminal connector for bent or broken pins. Make sure that all fasteners are securely tightened.

5-3. ERROR STATEMENTS

5-4. Certain calibration functions will cause error statements to be displayed if incorrectly performed. Refer to table 5-1 for an explanation of these statements.

5-5. CALIBRATION

5-6. The calibrator does not require recalibration. Its correct operation can be verified at the factory.

5-7. CUSTOMER SERVICE

5-8. Bird Electronic Corporation maintains a complete repair and calibration department at our corporate headquarters. This department is set up to provide the best possible service for Bird equipment.

5-9. All instruments returned for service must be shipped prepaid and marked to the attention of the Customer Service Group.

Bird Electronic Corporation
30303 Aurora Road
Solon, Ohio 44139-2794
Phone: 216-248-1200
Cable: BIRDELEC
Telex: 706898 Bird Elec UD
FAX: 216-248-5426

TABLE 5-1. ERROR STATEMENTS.

ERROR STATEMENT	POSSIBLE CAUSE
The command was ignored. Check the CAL ENABLE switch.	The CAL ENABLE/STANDBY switch is in the STANDBY position.
Power is too low to perform calibration.	The power sensor is installed backward in the RF line. The wrong calibration direction has been selected. The calibrating power is below 0.1% of full scale power.
Power sensor is unable to measure the frequency.	Calibration power is not at a stable frequency. Calibrating frequency is outside of power sensor frequency range.
Invalid calibration number.	The calibration number entered is not contained in the calibration list.

5-10. REPACKAGING

5-11. Should you need to ship the calibrator, use the original shipping package. If the original package is not available, pack the calibrator in a heavy duty corrugated box with shock absorbing material around all sides to prevent movement in the container.

5-12. TROUBLESHOOTING

Due to the complexity of the calibrator, troubleshooting is limited to the basic procedures listed below:

PROBLEM	POSSIBLE CAUSE	REMEDY
AC Lamp does not light when calibrator is switched on.	<ul style="list-style-type: none">• Line fuse is open. Defective line cord.• Line voltage selector set to wrong voltage.	<ul style="list-style-type: none">• Replace the fuse. Repair or replace the line cord.• Set the selector to the correct voltage.
No communication between the calibrator and CRT terminal.	<ul style="list-style-type: none">• Handshaking error.• Defective cable between the calibrator and CRT terminal.• DTE/DCE switch set in wrong position.• Data format switch switches set in wrong positions.	<ul style="list-style-type: none">• Consult your CRT terminal manual.• Repair or replace cable.• Determine correct position and set the switch. Refer to Paragraph 2-14.• Determine and correct the the settings.
No communication between calibrator power sensor.	<ul style="list-style-type: none">• Poor power sensor connection.• Defective power sensor cable.	<ul style="list-style-type: none">• Clean power sensor and calibrator connectors and check for bent or broken pins.• Repair or replace defective cable.

SECTION VI — REPLACEMENT PARTS

6-1. GENERAL

6-2. This section lists, describes, and illustrates the major component parts of the model 4029 Power Sensor Calibrator, manufactured by Bird Electronic Corporation, Cleveland (Solon), Ohio, 44139-2794.

6-3. PARTS ILLUSTRATION

6-4. An exploded view of the calibrator is provided in Figure 6-1 to illustrate the major components and their relationship to each other. An illustration of the PC board assembly is provided in Figure 6-2 and shows the individual component placement. Each figure has a corresponding parts list which contains a list of all the illustrated parts.

6-5. EXPLANATION OF COLUMNS

- a. The Figure & Item No. column lists the figure number of the illustration on which the part is located, and also gives the item number assigned to that part.
- b. The QTY. column contains the quantity of that part used per assembly.
- c. The Bird Part No. column contains the Bird Electronic Corporation part numbers.
- d. The Description column gives the name of the part or assembly, indented by columns to indicated relationship to the next higher assembly.

FIGURE 6-1. EXPLODED VIEW OF CALIBRATOR.

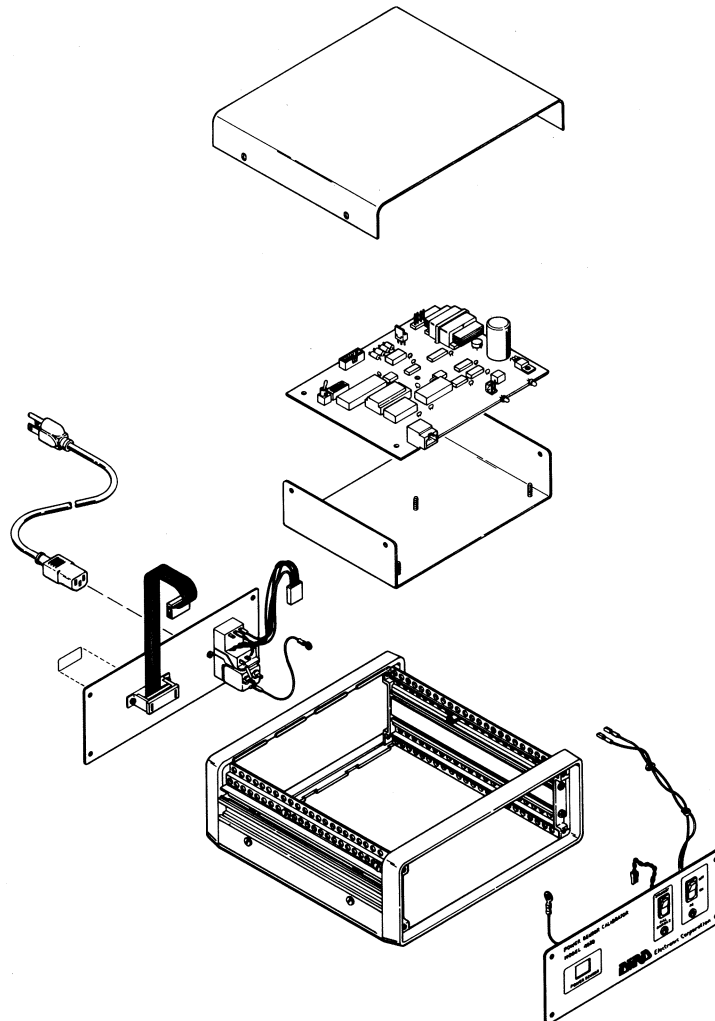

TABLE 6-1. CALIBRATOR PARTS LIST.

FIGURE & ITEM NO.	QTY.	BIRD PART NO.	DESCRIPTION
6-1	Ref	4029-001	Calibrator Assembly
-1	1	4029-014	Case
-2	1	4029-002	Front Panel Assembly
-3	1	4029-003	Rear Panel Assembly
-4	1	4381-063	Nameplate
-5	1	4029-008	P.C. Board Assembly
-6	5	5-1777	Spacer
-7	1	4029-013	Main Frame
-8	4	5-1776-2	Threaded Hex Spacer
-9	1	4421-055	115/230V Power Cord Assembly

FIGURE 6-2. PRINTED CIRCUIT BOARD ASSEMBLY.

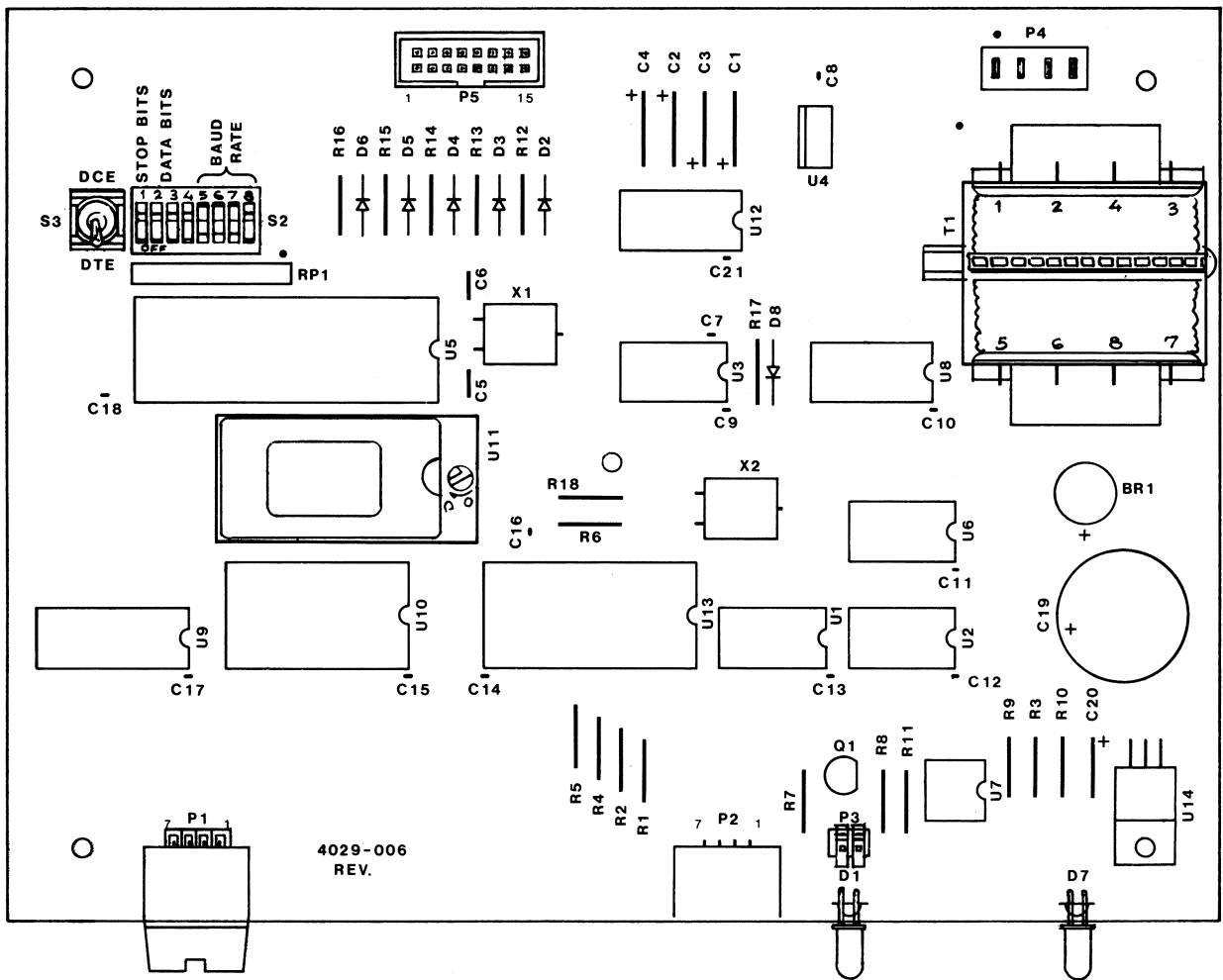

TABLE 6-2. P.C. BOARD ASSEMBLY PARTS LIST.

FIGURE & ITEM NO.	QTY.	BIRD PART NO.	DESCRIPTION
6-2	Ref	4029-008	PC Board Assembly
-1	1	4029-005	PC Board
-2	1	5-1793-7	Cable Tie
R1,R2,R4-R6, R12-R16	10	5-1520-103	Resistor, 10K Ω , 5%
R7	1	5-1520-271	Resistor, 270 Ω , 5%
R3,R8,R11	3	5-1520-102	Resistor, 1000 Ω , 5%
R9	1	5-157-4.99K	Resistor, 4.99K Ω , 1%
R10	1	5-157-10K	Resistor, 10K Ω , 1%
R17	1	5-1520-105	Resistor, 1M Ω , 5%
R18	1	5-1520-273	Resistor, 27K Ω , 5%
RP1	1	5-1289-2	Resistor Network, 10K \times 8
C1-C4, C20	5	5-1239	Capacitor, 10pF
C5,C6	2	5-1233-3	Capacitor, 18pF
C7-C18,C21	13	5-688-8	Capacitor, 0.1pF
C19	1	5-1623	Capacitor, 6800pF
D1	1	4029-017-1	Red LED
D2-D6,D8	6	5-1225	Diode, 1N4148
D7	1	4029-017-2	Green LED
BR1	1	5-1661	Bridge Rectifier
Q1	1	5-1090	Transistor, 2N3906
U1	1	5-1708	Logic I.C., 74HC132
U2	1	5-1709	Logic I.C., 74HC00
U3	1	5-1710	Logic I.C., 74HC14
U4	1	5-1100-1	Voltage Regulator, LM340T5
U5	1	5-1704	Microprocessor, 6303
Ref	1	5-1213	40 Pin Socket
U6	1	5-1768	Logic I.C., 74HC04
U7	1	5-1800	Power Monitor I.C.
U8	1	5-1707	Logic I.C., 74HC139
U9	1	5-1706	Logic I.C., 74HC573
U10	1	5-1705	Memory I.C., 6116
Ref	1	5-1307	24 Pin Socket
U11	1	4029-018	Programmed Memory I.C.
Ref	1	5-1801	28 Pin Zip Socket
U12	1	5-1787	Logic I.C.
Ref	1	5-1211	16 Pin Socket
U13	1	5-1660	Logic I.C., 6551
Ref	1	5-1619	28 Pin Socket
U14	1	5-1100-3	Voltage Regulator, LM340T12
X1	1	5-1702	4.9152MHz Crystal
X2	1	5-1423	1.8432MHz Crystal
T1	1	5-1772	Transformer
S2	1	5-1264-2	DIP Switch
S3	1	5-1266	Toggle Switch
P1	1	5-1703	8 Pin Connector
P3	1	5-1712-2	2 Pin Connector
P4	1	5-1723-1	4 Pin Header
P5	1	5-1723-2	16 Pin Connector

APPENDIX A. — USING AN IBM COMPUTER AS A TERMINAL

A-1. GENERAL

A-2. This section details the use of an IBM PC or XT computer as a CRT terminal. The computer must be equipped with an asynchronous RS-232-C communication adapter, DOS Version 2.0 (or later) operating system, and Basic (or BASICA).

A-3. DIRECTIONS

A-4. The program is set up to operate over the COM 1 serial channel at 9600 baud, 8 data bits, and 1 stop bit. Connect the calibrator to the computer by

following the instructions in Paragraph 2-11. Follows the steps to enter the program into your computer.

1. Type BASICA followed by return on the computer keyboard to load the IBM interpretive BASIC language.
2. Enter the program as listed in Figure A-1. Be sure to hit return at the end of each line.
3. Type RUN followed by return to start the program.
4. Press the F1 key when finished to end the program.

FIGURE A-1. TERMINAL PROGRAM FOR IBM PC OR XT COMPUTER.

PROGRAM	COMMENTS
10 SCREEN 0,0:CLS	SET SCREEN AND CLEAR IT.
20 FALSE=0: TRUE=NOT FALSE	DEFINE FLAGS.
30 ON ERROR GOTO 220	
40 XOFF\$=CHR\$(19):XON\$=CHR\$(17)	DEFINE XON/XOFF.
50 OPEN "COM1:9600,N,8,1,RS,CS" AS #1	FILE #1 IS COM1, 9600 BAUD.
60 KEY 1,"DONE"+CHR\$(13)	8 DATA BITS, 1 STOP BIT.
70 OPEN"SCRN:" FOR OUTPUT AS#2	FILE #2 IS CRT DISPLAY.
80 LOCATE,,1	
90 FULL=FALSE	START WITH XON FLAG=OK.
100 B\$=INKEY\$:IF B\$ < > "" THEN PRINT #1, B\$;	IF NOT A NULL, SEND TO COM.
110 ON ERROR GOTO 230	
120 IF B\$="D" THEN 240	CHECK IF DONE.
130 IF EOF(1) THEN 100	WAIT FOR CHAR TO BE TYPED.
140 IF LOC(1) > 128 THEN FULL=TRUE:PRINT#1,XOFF\$;	
150 A\$=INPUT\$(LOC(1),#1)	GET CHAR WHICH CAME IN.
160 LFP=0	
170 LFP=INSTR(LFP+1,A\$,CHR\$(10))	
180 IF LFP > 0 THEN MID\$(A\$,LFP,1)=" ":GOTO 170	
190 PRINT #2,A\$; :IF LOC(1) > 0 THEN 140	DISPLAY INCOMING CHARS.
200 IF FULL THEN FULL=FALSE; PRINT#1,XON\$;	ALLOW IN CHAR IF ROOM IS AVAILABLE.
210 GOTO 100	
220 RESUME 50	
230 IF ERR=57 AND INKEY\$ < > "D" THEN RESUME	
240 PRINT:FOR X=1 TO 4:B\$=INKEY\$:NEXT X:PRINT:PRINT"DONE"	
250 CLOSE #1	
260 END	

NOTES

NOTES

LIMITED WARRANTY

All products manufactured by Seller are warranted to be free from defects in material and workmanship for a period of one (1) year, unless otherwise specified, from date of shipment and to conform to applicable specifications, drawings, blueprints and/or samples. Seller's sole obligation under these warranties shall be to issue credit, repair or replace any item or part thereof which is proved to be other than as warranted; no allowance shall be made for any labor charges of Buyer for replacement of parts, adjustment or repairs, or any other work, unless such charges are authorized in advance by Seller.

If Seller's products are claimed to be defective in material or workmanship or not to conform to specifications, drawings, blueprints and/or samples, Seller shall, upon prompt notice thereof, either examine the products where they are located or issue shipping instructions for return to Seller (transportation-charges prepaid by Buyer). In the event any of our products are proved to be other than as warranted, transportation costs (cheapest way) to and from Seller's plant, will be borne by Seller and reimbursement or credit will be made for amounts so expended by Buyer. Every such claim for breach of these warranties shall be deemed to be waived by Buyer unless made in writing within ten (10) days from the date of discovery of the defect.

The above warranties shall not extend to any products or parts thereof which have been subjected to any misuse or neglect, damaged by accident, rendered defective by reason of improper installation or by the performance of repairs or alterations outside of our plant, and shall not apply to any goods or parts thereof furnished by Buyer or acquired from others at Buyer's request and/or to Buyer's specifications. In addition, Seller's warranties do not extend to the failure of tubes, transistors, fuses and batteries, or to other equipment and parts manufactured by others except to the extent of the original manufacturer's warranty to Seller.

The obligations under the foregoing warranties are limited to the precise terms thereof. These warranties provide exclusive remedies, expressly in lieu of all other remedies including claims for special or consequential damages. SELLER NEITHER MAKES NOR ASSUMES ANY OTHER WARRANTY WHATSOEVER, WHETHER EXPRESS, STATUTORY, OR IMPLIED, INCLUDING WARRANTIES OF MERCHANTABILITY AND FITNESS, AND NO PERSON IS AUTHORIZED TO ASSUME FOR SELLER ANY OBLIGATION OR LIABILITY NOT STRICTLY IN ACCORDANCE WITH THE FOREGOING.

Note

To keep this manual as current and accurate as possible, Bird Electronic Corporation recommends that you periodically request the latest manual changes supplement. Complimentary copies of the supplement are available from Bird.

MODEL COVERED IN THIS INSTRUCTION BOOK

4029

